

Instructions

Pressure Controls PS12C1

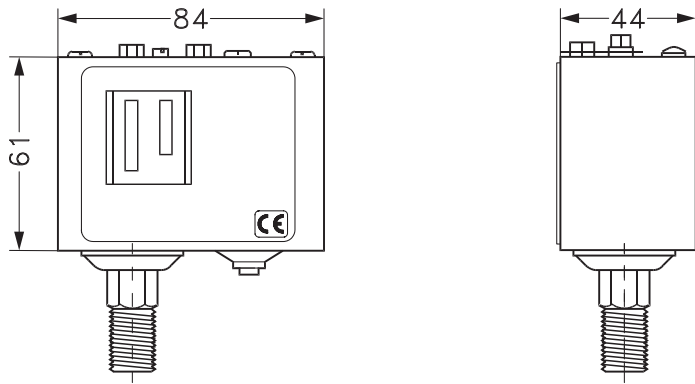

PS12C1
 t_1 min. -40 °C
 t_1 max. 65°C
 t_2 min. -40 °C
 t_2 max. 100°C
 p_{est} max.
 PS12C1: 22 bar

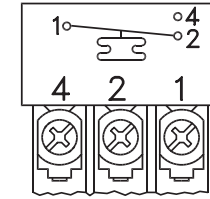
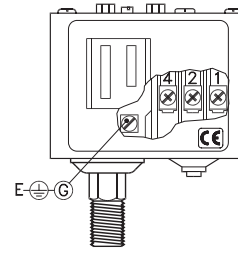
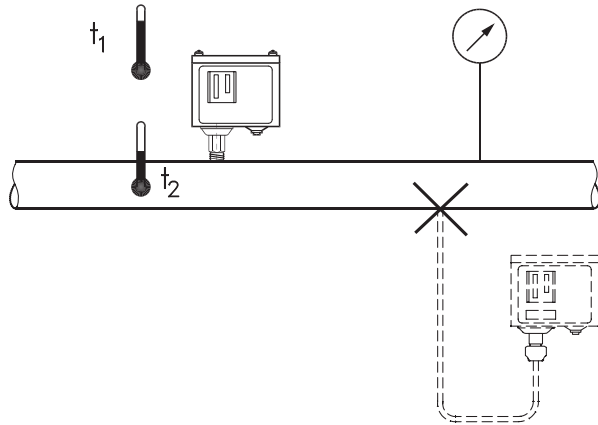

Contact system with standard AG contacts
 Single pole changeover switch (SPDT)

Alternating current:
AC-1: 16, 400 V
 AC-3: 16A, 400 V
 AC-15: 10A, 400 V

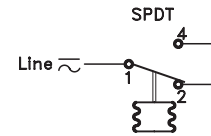

Contact system with gold contacts
 Single pole changeover switch (SPDT)

Alternating current:
 AC-1: 10, 400 V
 AC-3: 6A, 400 V
 AC-15: 4A, 400 V

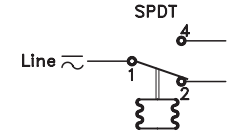

Direct current:
 DC-13: 12W, 220 V

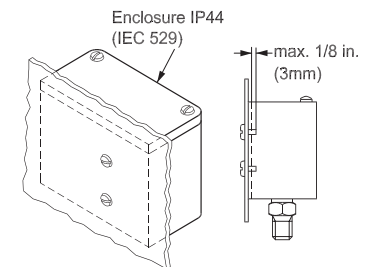
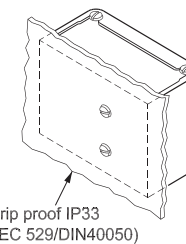
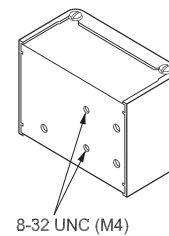
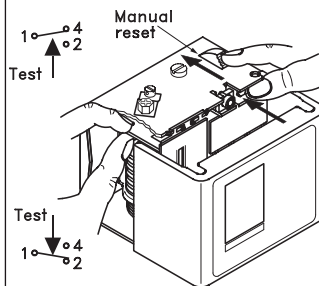
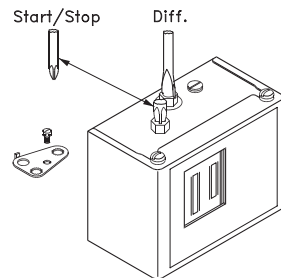
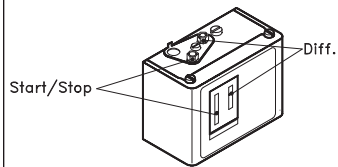
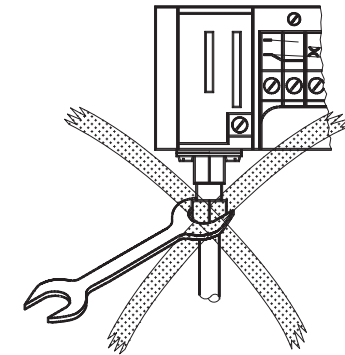
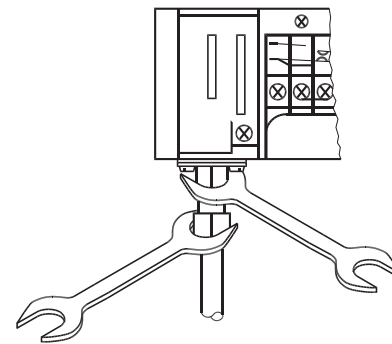

CAUTION: The mounting panel must be plane to avoid damage of control