

# S71-S72

## Gas detection sensors for control units P30A and P70

Combustible gas detection sensors to be used with the electronic control units P30A and P70. The sensors are available in 2 versions: S71 for methane gas and city gas, S72 for LPG.

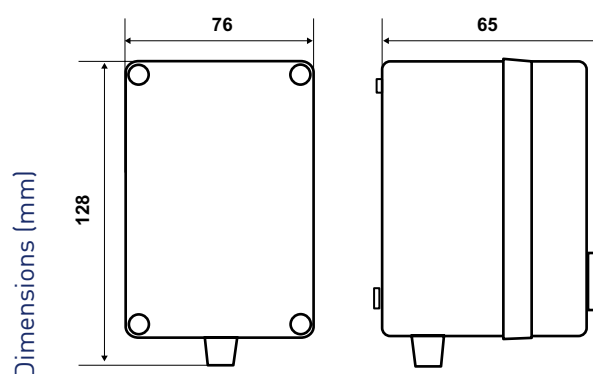
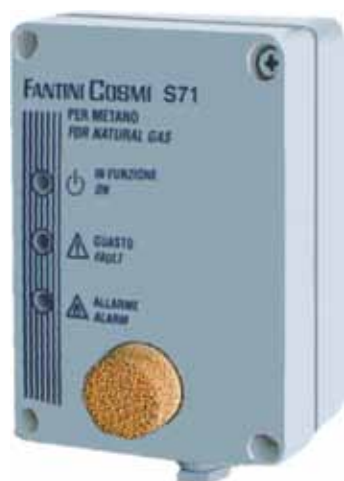

| Gas type   | Operating ambient temperature °C | Protection degree |
|--|----------------------------------|-------------------|
| S71 methane gas, or other light gases                  | - 10 ÷ 50                        | IP54              |
| S72 LPG gas (cylinder liquid gas) or other heavy gases | - 10 ÷ 50                        | IP54              |

## INSTALLATION

Wall mounting.

Detection sensors should be fixed on the wall at a distance of approximately 2 meters from the gas using device in such position in order to allow natural air circulation:

- S71 for specific light gases (methane gas, city gas), this sensor has to be installed at a high level approximately 30-40 cm from the ceiling.
- S72 for heavy gases (cylinder liquid gas LPG), this sensor has to be installed to a low level approximately 30-40 cm above the floor.

Avoid installing the sensors:

- behind barriers that hinder the air natural circulation in the environment.
- near vents (keeping a minimum distance of 2 meters).
- away from steam, smoke and other fumes.

Remove the cover by unscrewing the four front screws.

Install the base on the wall using for the cable input the appropriate cable gland.

## OPERATION

The intervention threshold of the sensors is adjusted in the factory to a value that allows the signaling of gas presence at a concentration much lower than the danger limits.

The sensors are provided with an intervention light signaling and the connections with the control unit have positive safety (their disconnection causes the detector intervention).

### CONTROL UNIT

- A Voltage indicator: always switched on.
- B Sensor failure indicator.
- C Alarm sensor indicator: normally switched off, it operates and remains on for all the time during which the detected gas concentration is above the prescribed value.

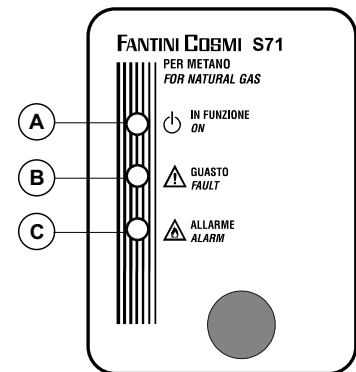

## ELECTRICAL CHARACTERISTICS

Casing in shockproof insulating material.

Green LED to indicate power supply.

Red LED to indicate triggering.

Orange LED to indicate sensor failure.

Positive safety connections with the detector (the control unit detects an error, in case of incorrect connections or interruption of the connection).

Unit weight 0,18 Kg.