

EV80

Digital controller for heating systems with remote control

The unit regulates water delivery temperature of the heating systems. It is suitable for all heating systems types of apartment buildings, factories, schools, cottages, etc.

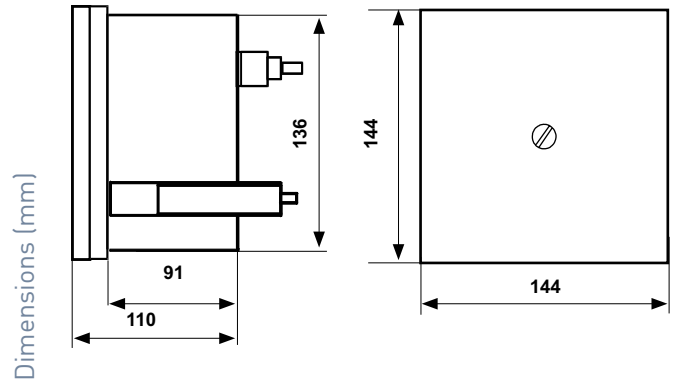

	Contacts rating	Power supply	Operation admissible temperature °C	Protection degree
EV80	5A - 250Vca	230Vca 50 Hz	0 ÷ 50	IP40

ELECTRICAL FEATURES

Power supply: 230Vca 50Hz.

Consumption: 7 VA.

Contacts rating 5A- 230Vca (resistive load).

2 optoisolated alarm inputs to prevent interference.

1 communication channel RS232 for connection to a modem or directly to a computer.

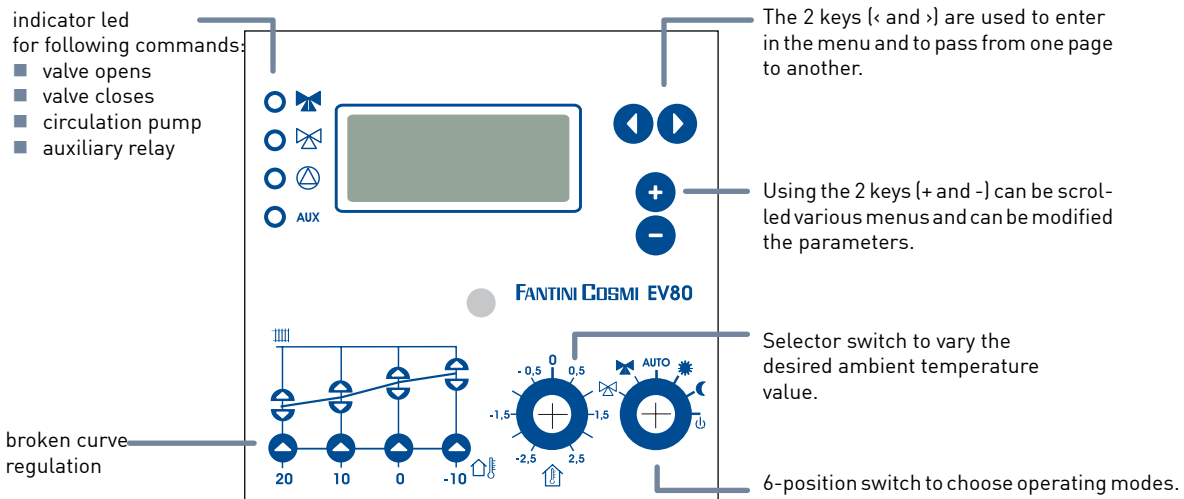

ELECTRICAL DIAGRAM FOR THE CONTROL OF THE MOTORIZED MIXING VALVES WITH SERVOCONTROLS SUPPLIED AT 230V 50HZ

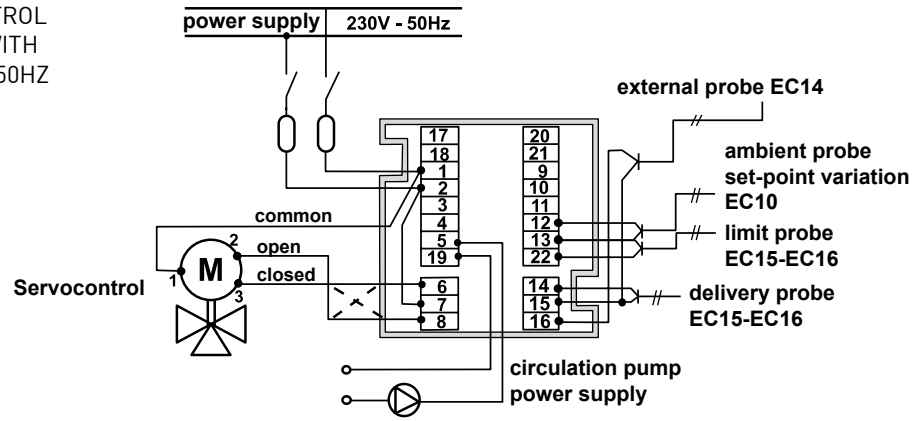

ELECTRICAL DIAGRAM FOR THE ON - OFF CONTROL OF THE 2-STAGE BURNER

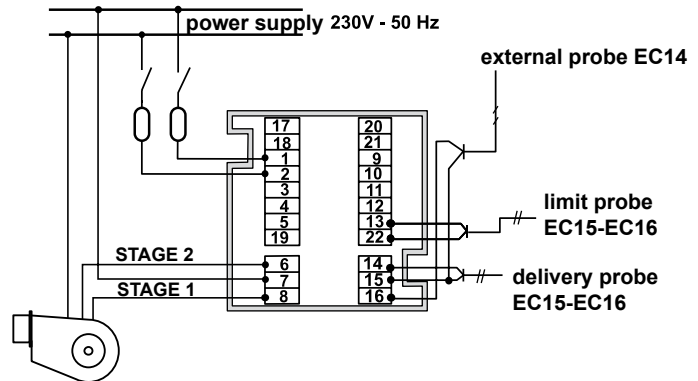

ELECTRICAL DIAGRAM FOR THE ON - OFF CONTROL OF THE 4-STAGE BURNER

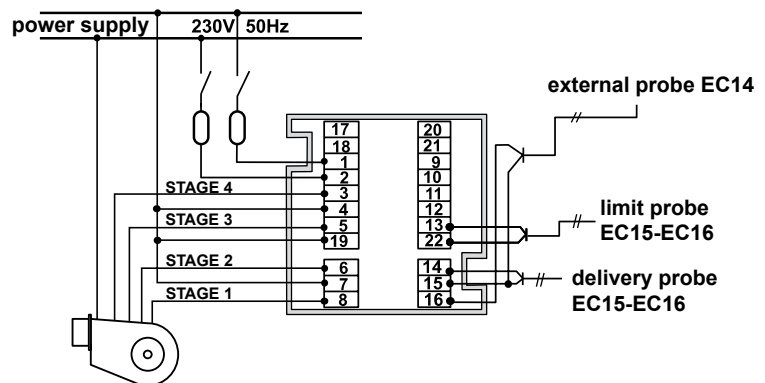

OPERATION

The controller calculates the delivery temperature value as a function of the following parameters:

- external temperature (detected by the probe);
- regulation broken curve (set);
- ambient temperature calculated by the controller (optional);
- ambient temperature detected by the ambient probe (optional).

By means of controller it is possible to choose the desired output type:

- mixing valve control (relay "opens" and "closes");
- 2-stage output (relay "opens"=stage 1 and "closes"=stage 2);
- 4-stage output (relay "opens"=stage 1, "closes"=stage 2, "pump"=stage 3 and "aux"=stage 4).

N.B. with 4-stage operation the two relays (pump control and auxiliary) cannot be used for another purposes.

It compares the theoretical (calculated) delivery temperature value with the real value, measured by the relative probe and acts on the regulation valve to obtain the desired temperature.

Programming can be made via GSM phone.

LANGUAGE SELECTION

During installation is possible to choose the language, used to view the menu.

REGULATION BROKEN CURVE

The broken curve adjustment is set through 4 keys that allow to change quickly the delivery temperature relative to 4 significant values of the external temperature (20°C; 10°C; 0°C; -10°C).

The relation that establishes the delivery temperature value as a function of the external temperature depends of the thermal features of the building, and for optimum comfort, must be found experimentally.

The search is favored by the broken curve in 4 points, which may be corrected only in the desired point.

After each adjustment, while setting the regulation curve to obtain the desired ambient temperature for any external temperature value, it is advisable to wait at least 24 hours for giving to the system time for adapting to the new settings.

To have a different ambient temperature, for example night temperature, the curve must be moved parallel to the day curve.

ALPHANUMERIC DISPLAY

All parameters are modified using two keys (+ and -) and the values are displayed on the alphanumeric display with 4 lines by 16 characters. Two other keys are used to pass from one parameter to another and to scroll through the various configuration menus.

SWITCH-ON TIME OPTIMIZATION

Optimization is intended as automatic determination of the switch-on advance time required to obtain the desired ambient temperature at the preset time. When this function is activated, instead of setting the switch-on time, is set the time at which the desired day ambient temperature is required; then the controller, as a function of the various parameters, calculates how much time earlier has to be activated the system.

OPTIMIZATION AS A FUNCTION OF THE EXTERNAL TEMPERATURE, it is advisable in cases in which there are no weekly shut-down times (apartment buildings, cottages, etc.).

After setting the relation that links the advance time to 4 external temperature values (20, 10, 0, -10°C), the controller automatically calculates the time for any intermediate value of the external temperature (for external temperature values of over 20°C the advance time is zero).

OPTIMIZATION AS A FUNCTION OF ALL PARAMETERS, suitable in cases in which there are weekly shut-down times (schools, offices etc.).

The controller calculates the advance time as a function of the:

- virtual ambient temperature;
- external temperature;
- time constant of the building;
- time since the last switch-on.

The "RECORDER" function also records the course of the various temperatures (external, delivery, auxiliary, virtual ambient) in about one and a half days.

With these data is possible to find, experimentally, the time constant value suitable for each system; the preset times relative to the external temperature keys 20, 10, 0, -10°C, in this case, are used as maximum advance limit relative to that external temperature value.

REGULATION BROKEN CURVE

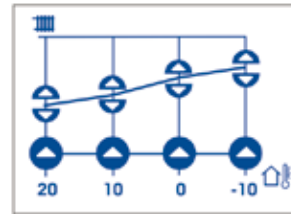
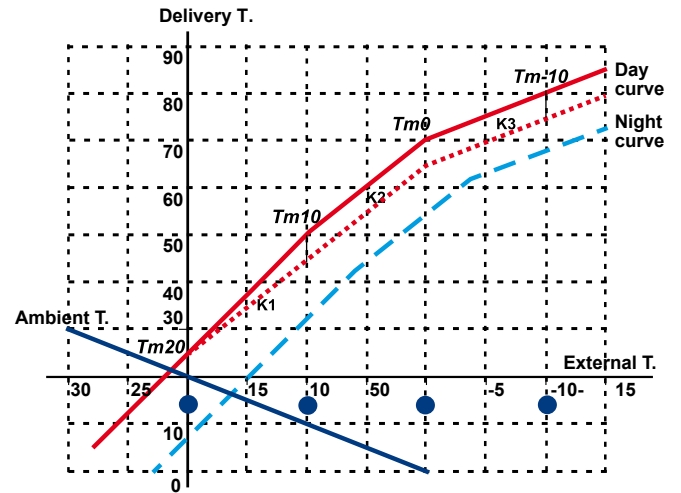

SWITCH-ON TIME OPTIMIZATION

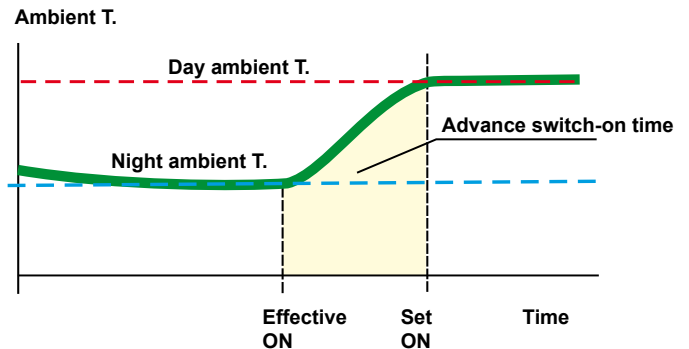

OPTIMIZATION AS A FUNCTION OF THE EXTERNAL TEMPERATURE

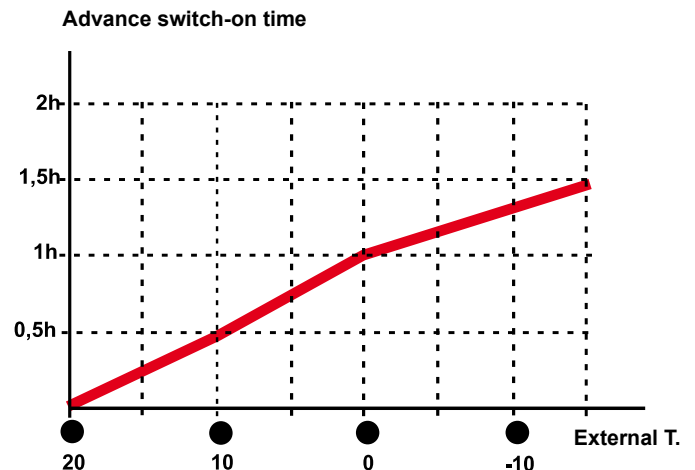

DYNAMIC REGULATION

In most heat controllers the delivery temperature is calculated as a function only of the external temperature, ignoring the time constant of the building, rather each variation of the water delivery temperature uses a longer or shorter time to obtain its effect.

In the EV80 controller it is possible to take account of this variable by setting the time constant value.

The time constant parameter is used by the controller to calculate a virtual ambient temperature (visible in the same menu) which represents the average ambient temperature course, even without a measurement probe.

It is possible to give a value to this temperature and use it in the regulation to calculate the delivery temperature as a function of the external temperature (measured) and the virtual ambient temperature (calculated as a function of inertia) which is affected by the delays caused by the system structure.

NORMAL REGULATION

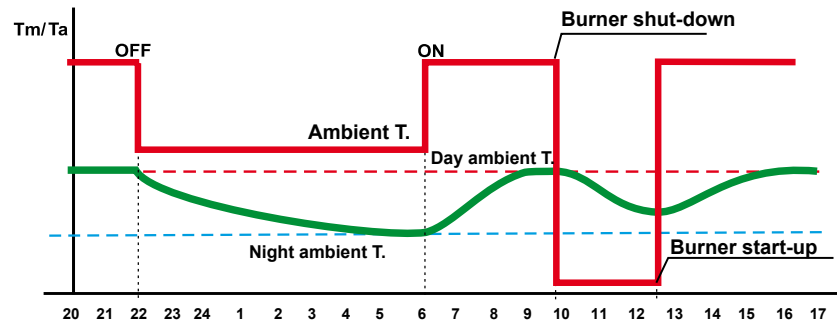

DYNAMIC REGULATION

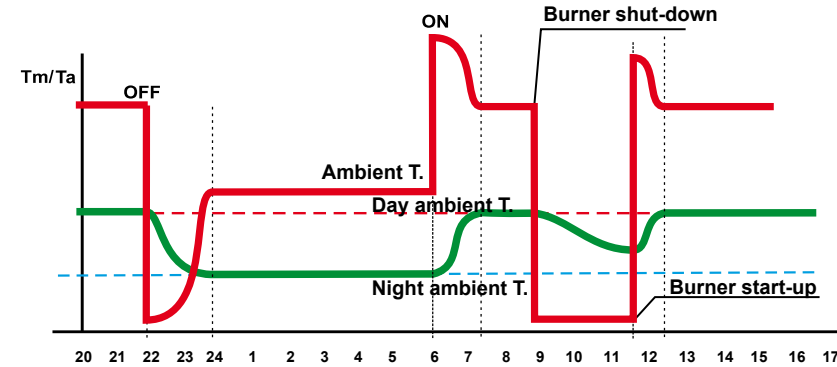

With this function activated it can be observed, for example, that during passing from day to night operating mode the controller closes the valves to wait for the ambient temperature to drop to the desired value and then starts to regulate according to the programmed reduced temperature data.

During the switch-on phase in the morning the controller provides more heat to restore the heat lost during the night, comparing the virtual ambient temperature value with the preset day temperature. The controller action is the same if there is a burner shut-down during the day.

By setting the time constant to zero (=0), this function is excluded and the controller behaves like a traditional instrument which does not take into account the time function.

REMOTE CONTROL

By connecting the EV80 controller to a GSM modem it is possible to receive SMS alarm messages after switching one of the two available alarm contacts.

For connecting the controller to a GSM modem, follow the instructions relative to the wiring diagram, or use the TCEV80 cable. N.B. The maximum length between the controller and the modem is 15 meters.

If the management takes place through a GSM modem is sufficient to use a cell phone.

If is used a GSM modem in data mode, it is necessary to use a Personal Computer with a control software available only in Italian language provided by Fantini Cosmi or downloaded via Internet.

By sending appropriate SMS messages to the modem connected to the controller is possible to read and modify remotely the following parameters:

- times programming;
- day, night and antifreeze temperature settings;
- regulation broken curve values;
- auxiliary preset temperature;
- measured temperatures reading;
- alarm calls cancellation.

DATA CONNECTION

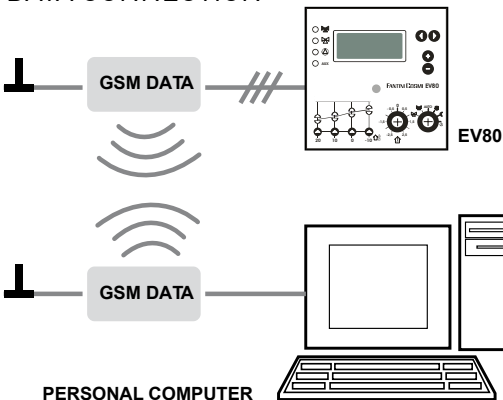

SMS CONNECTION

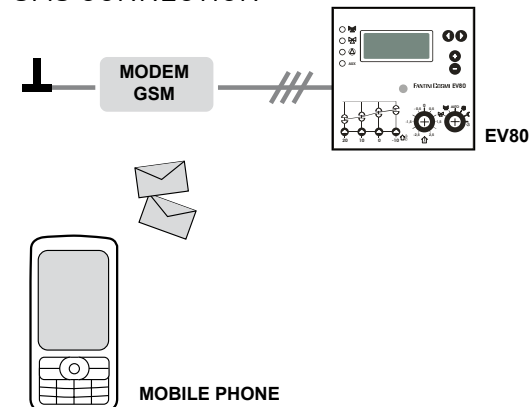

AUXILIARY CONTROLLER

In the same device is inserted an auxiliary controller with ON-OFF control, which can be used, for example, to adjust the temperature of sanitary hot water. The auxiliary measurement probe and the control relay (terminals 3-4) are part of an auxiliary controller built into the EV80 remote heat controller which can be used in various ways:

- Measurement probe not connected: the output relay (terminals 3-4) follows the time programming of the clock and can be used, for example, to switch the boiler on or off; it is mandatory to set ---- on the desired value (menu M1).
- Measurement probe connected (terminals 12-13): this mode provides an ON-OFF thermostat with remote probe.
- From the menu M1 the fixed temperature option can be selected to control the pump of a domestic hot water storage tank at a constant temperature or, again from the menu M1 by selecting the sliding temperature option, a controller is obtained to control the boiler at a sliding temperature (in this case the set point value represents the amount of degrees the boiler must be regulated above the delivery temperature calculated by the heat controller).
- The control relay (terminals 3-4) is placed in series to the users (pump or boiler).

EVENTS RECORDER

Records the temperatures and the events of the last 48 hours (datalogger).

CIRCULATION PUMP CONTROL

With switch-off delay.

DIGITAL CLOCK WITH CHARGE RESERVE OF 5 YEARS

PROGRAMS SWITCH used for:

- passing easily from automatically to manual operating mode: always day, night, antifreeze;
- checking valve movement (first two positions: valve closes, valve opens).

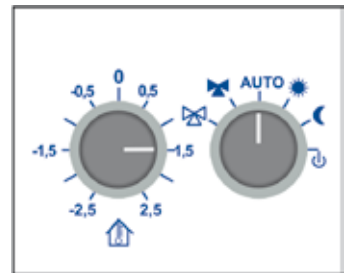

- VALVE CLOSES
- VALVE OPENS
- AUTO** AUTOMATIC OPERATION
- ALWAYS DAY
- ALWAYS NIGHT
- ANTIFREEZE

SWITCH FOR TEMPERATURE MANUAL CORRECTION

At any time is possible to correct the daily ambient temperature value up to a maximum of $\pm 2,5^{\circ}\text{C}$, simply by moving the front potentiometer.

STANDARDS AND HOMOLOGATIONS

Complies with the law 373, law n.10 dated 9 of January 1991 and D.P.R.412 dated 26 of August 1993.
In conformity with EN 60730-2-9; EN 60730-2-7 standards.

INSTALLATION

CONTROL UNIT with fast coupling to the base with FASTON connections. Application possibilities: wall, rear panel and flush mounting.

WALL MOUNTING

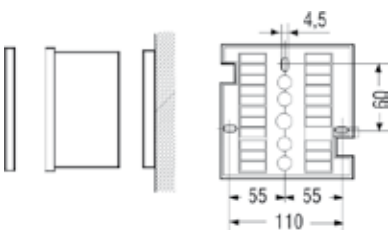

REAR PANEL MOUNTING

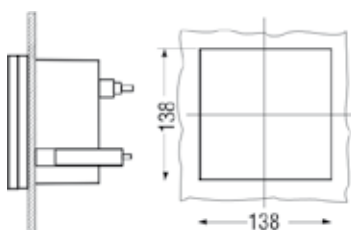

FLUSH MOUNTING

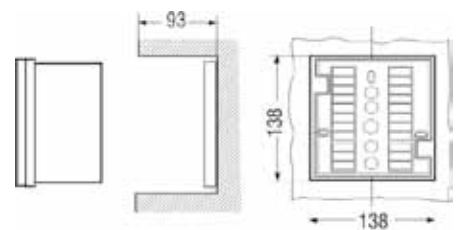

FEATURES

Control of 1 modulating mixing valve.

Control of the circulation pump (with shut-down delay).

Control of one ON-OFF auxiliary user (domestic water).

Switch-on times optimization, enabled or disabled for choice.

Two generic alarm inputs (optoisolated) used to notify any system malfunctions.

1 RS232 communication channel for connection to a modem or directly to a PC.

Weekly programming with 3 time bands per day.

LED to indicate relays status.

Clock charge reserve: over 5 years.

Alphanumeric display with 4 lines each with 16 characters with timed backlighting.

Program selector switch (6 positions).

Selector switch for manual adjustment of the day ambient temperature ($\pm 2,5^{\circ}\text{C}$).

ACCESSORIES



EM70S

GSM-modem with power supply unit and antenna.



N70A

Power supply unit and battery charger.



1590029

Rechargeable battery 12V-1,2Ah.



EC10

Ambient probe



EC14

External probe



EC15

Contact delivery probe with clamp for fixing on the pipe.



EC16

Immersion delivery probe with protection casing and conic thread connection G 1/2.

SYSTEM EXAMPLES

SYSTEM WITH 3-WAY ROTOR MOTORIZED VALVE

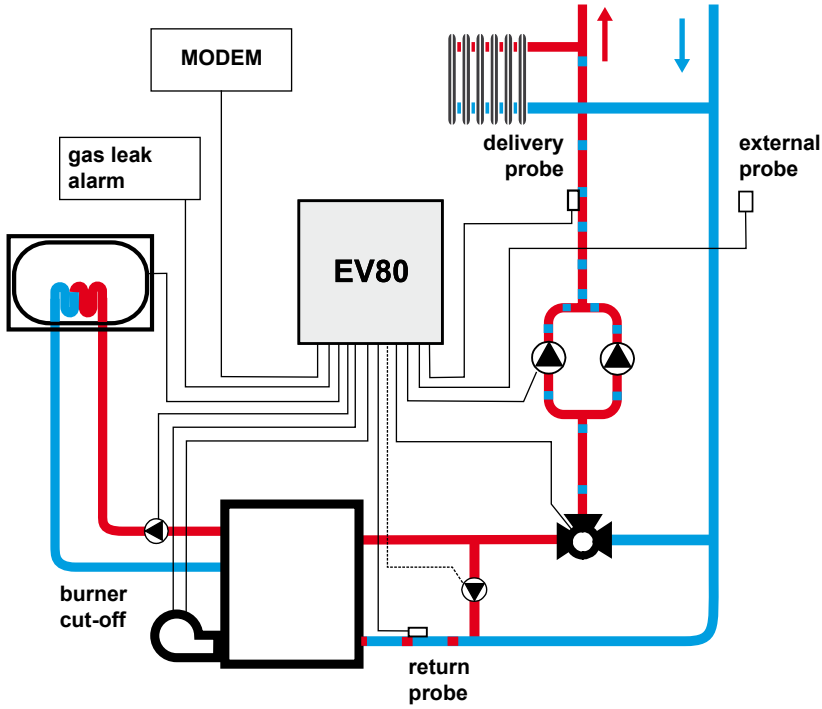

SYSTEM WITH 4-WAY ROTOR MOTORIZED VALVE

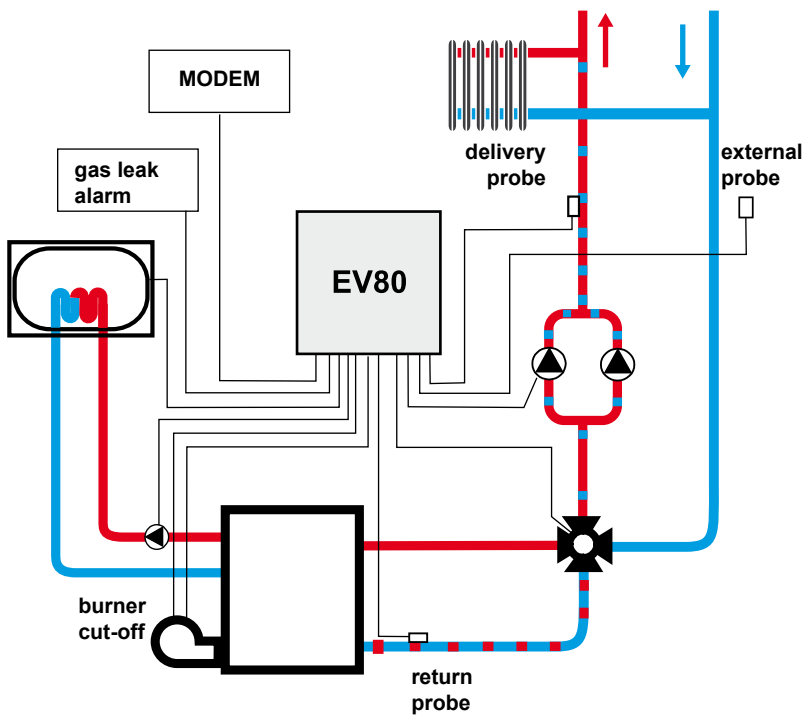

SYSTEM EXAMPLES

SYSTEM WITH 3-WAY SECTOR MOTORIZED VALVE

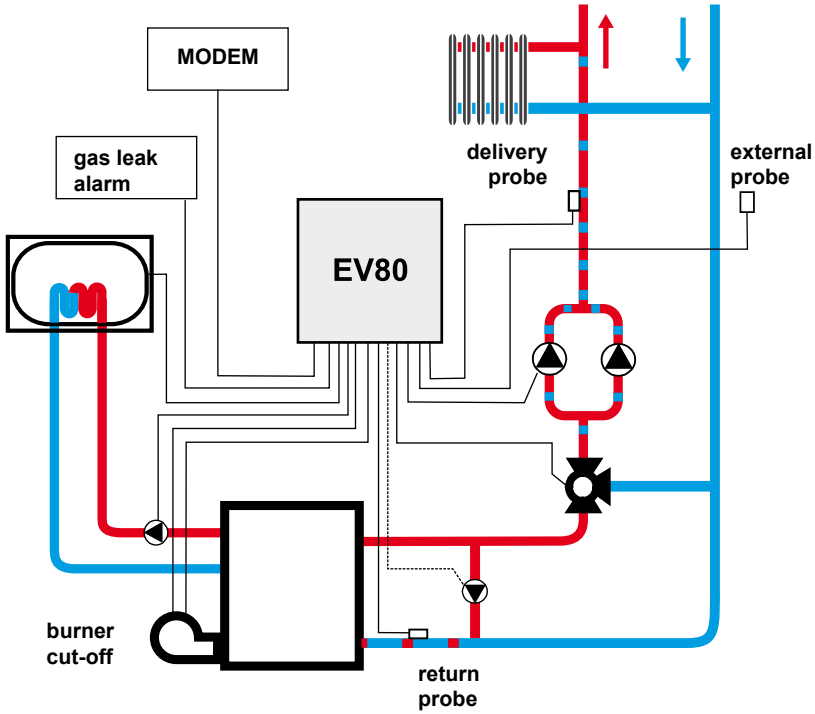

SYSTEM WITH BURNER CONTROL

