

DESCRIPTION

Valves series "UK" are produced in the 2/2, 3/2 and 5/2 monostable pneumatic functions. In the 3 port solenoid control version with small pilot system, sizes G 1/8 and G 1/4, support the 15 mm direct acting solenoid valve (type UMCSV with fixed position). All the other electric versions can support the 32 mm direct acting solenoid valve, type ULCSV/R (with fixed position), type C/USCSVG with sleeve Ø 9 mm (with fixed position and rotatable coils series USB and USBG) or the amplifier valve XVF4 for a sensible pneumatic piloting (see page 3.36). The 3/2 N.C. pilot actuated valves can also be used to switch vacuum thanks to a suitably reinforced spring.

The poppet design assures high flow and high life. This series of valves, in the sizes G 1/8, G 1/4 and G 1/2, is prearranged for base mounting with conveyed inlet by means of rear notch screws.

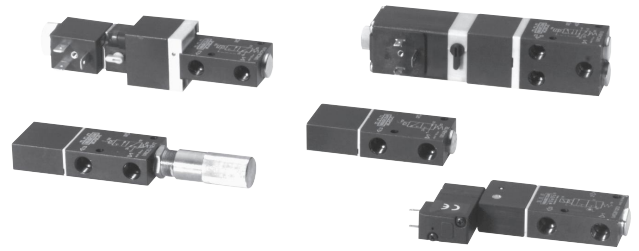

TECHNICAL DATA

Operating pressure	Solenoid actuated: 1,5 ÷ 10 bar Pilot actuated: 1,5 ÷ 12 bar
Working temperature	0 ÷ +70 °C (-20 °C with dry air)
Fluid	Filtered, unlubricated or lubricated compressed air - vacuum
Port size	G 1/8 - G 1/4 - G 1/2 - G 1
Pneumatic piloting port size	G 1/8
Nominal diameter	G 1/8 = 6 mm; G 1/4 = 8,5 mm; G 1/2 = 12 mm; G 1 = 23 mm
Piloting solenoid valves	UMCSV - see chapter Direct acting solenoid valves on page 2.3 ULCSV/R - see chapter Direct acting solenoid valves on page 2.6 C/USCSVG - see chapter Direct acting solenoid valves on page 2.13
Pneumatic piloting valve	XVF4 - see chapter Complementary valves on page 3.37
Coils (only for C/USCSVG)	USB - see chapter Coils on page 2.14 USBG - see chapter Coils on page 2.14
Electric connectors	USR 102/N9 - see chapter Connectors on page 2.15 ULR1B - see chapter Connectors on page 2.15 MEK 192/N - see chapter Connectors on page 2.15

MATERIALS

Control rod	Hardened and nickel-plated steel
Body	Anodized aluminium alloy
Springs	Stainless steel
Seals	NBR rubber
Bush rod	Brass
Piston	Acetal resin
Terminal strip	Acetal resin
Washer	Brass
End plug	Nickel-plated brass
Clamping screws	Steel

PILOTING CHART - UK G 1/8

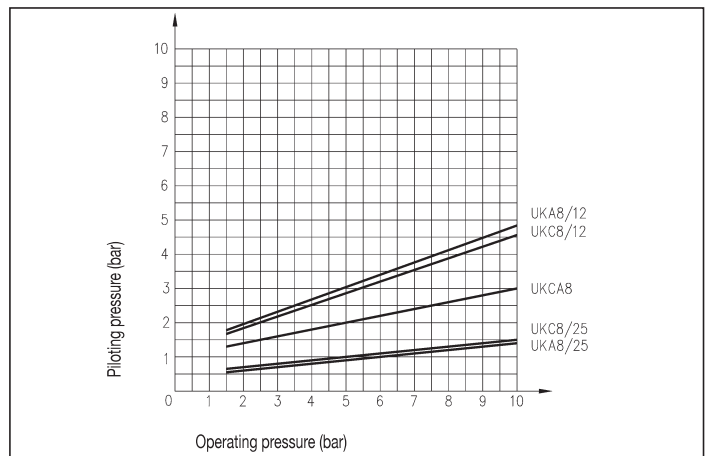

FLOW CHART - UK G 1/8 - 5/2

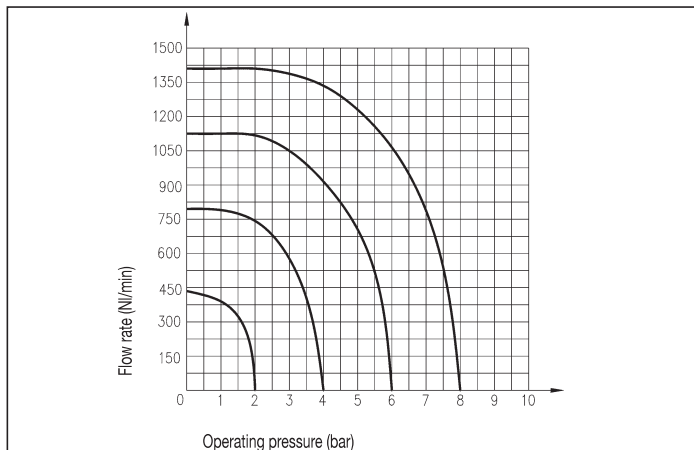

PILOTING CHART - UK G 1/4

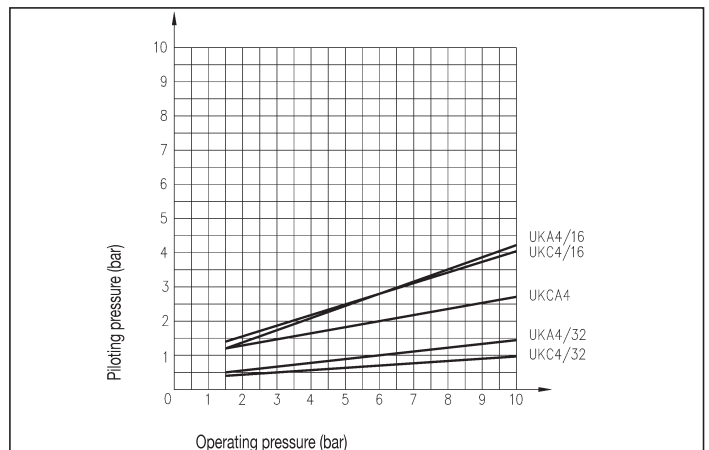

FLOW CHART - UK G 1/4 - 5/2

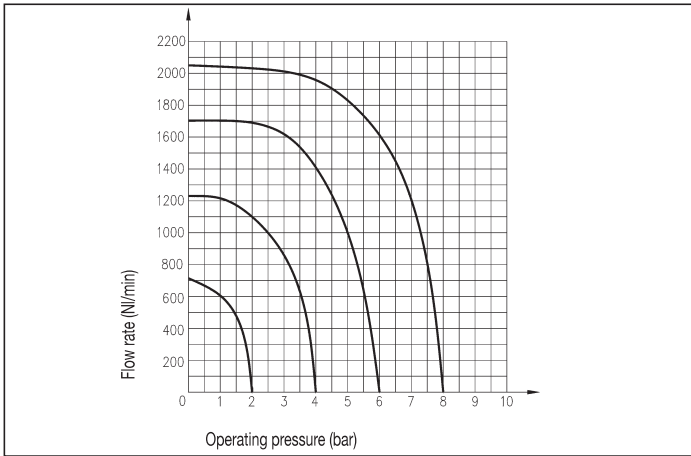

PILOTING CHART - UK G 1/2

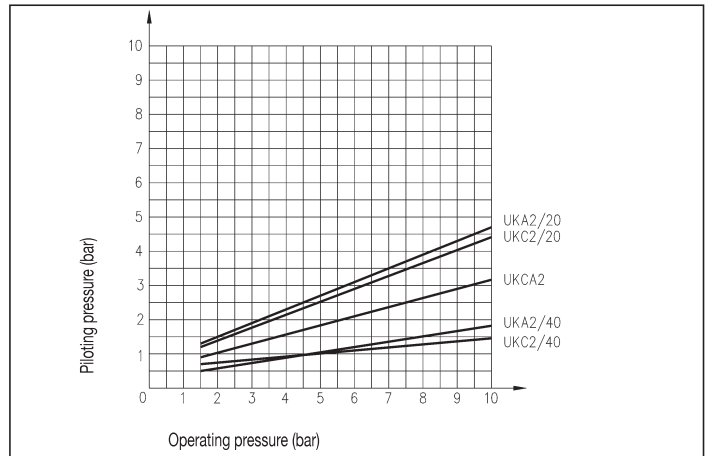

FLOW CHART UK - G 1/2 - 5/2

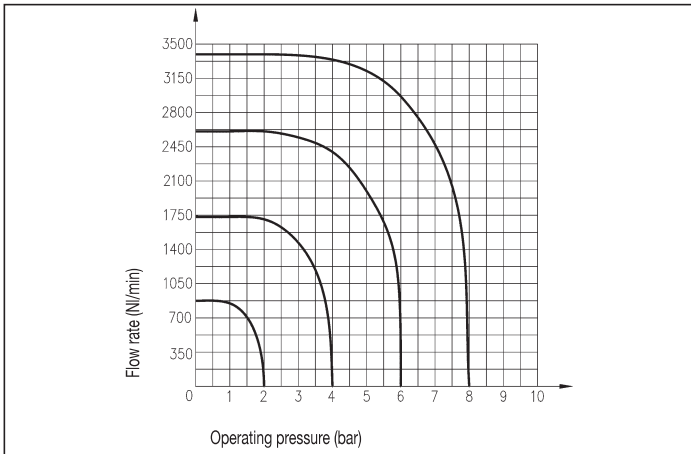

PILOTING CHART - UK G 1

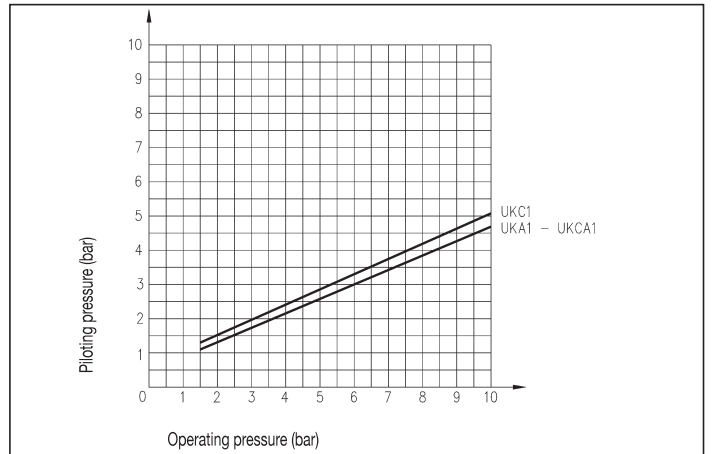

FLOW CHART - UK G 1 - 5/2

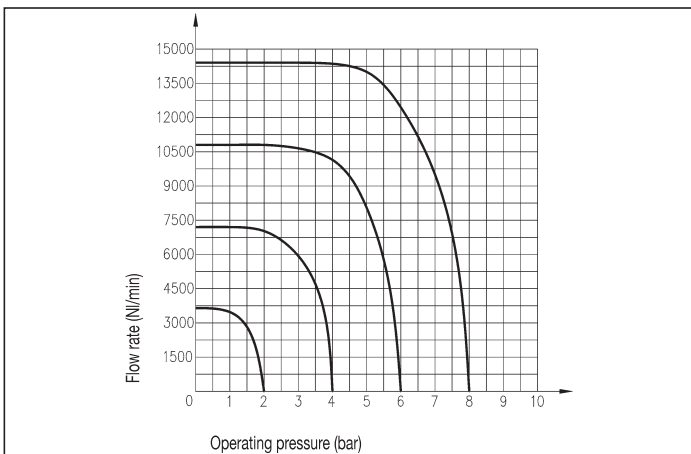

SPARE PARTS

SEALS KIT

3/2 N.O. G 1/8 small pilot system	UKA/12/SG/8
3/2 N.C. G 1/8 small pilot system	UKC/12/SG/8
3/2 N.O. G 1/8 big pilot system	UKA/25/SG/8
3/2 N.C. G 1/8 big pilot system	UKC/25/SG/8
5/2 G 1/8	UKCA/SG/8
3/2 N.O. G 1/4 small pilot system	UKA/16/SG/4
3/2 N.C. G 1/4 small pilot system	UKC/16/SG/4
3/2 N.O. G 1/4 big pilot system	UKA/32/SG/4
3/2 N.C. G 1/4 big pilot system	UKC/32/SG/4
5/2 G 1/4	UKCA/SG/4
3/2 N.O. G 1/2 small pilot system	UKA/20/SG/2
3/2 N.C. G 1/2 small pilot system	UKC/20/SG/2
3/2 N.O. G 1/2 big pilot system	UKA/40/SG/2
3/2 N.C. G 1/2 big pilot system	UKC/40/SG/2
5/2 G 1/2	UKCA/SG/2
3/2 N.O. G 1	UKA/SG/1
3/2 N.C. G 1	UKC/SG/1

2

PILOT ACTUATED VALVES* G 1/8 - 2, 3 and 5 PORT

Symbol	Function	Controls		Response time at 6 bar (ms)		Flow rate at 6 bar $\Delta P = 1 \text{ bar (NI/min)}$	Weight (g)	TYPE*
		Pilot	Return	Energized	De-energized			
	3/2 N.O. monostable	Small pneumatic	Mechanical spring	18	34	700	115	UKA 8/12
	3/2 N.C. monostable	Small pneumatic	Mechanical spring	20	29	700	115	UKC 8/12
		Servo fed small pneumatic	Mechanical spring	20	29	700	115	UKC 8/12/SA
		Adjustable small pneumatic	Mechanical spring	-	-	700	180	UKC 8/12/T
	3/2 N.O. monostable	Big pneumatic	Mechanical spring	18	38	700	135	UKA 8/25
	3/2 N.C. monostable	Big pneumatic	Mechanical spring	18	38	700	135	UKC 8/25**
		Servo fed big pneumatic	Mechanical spring	18	38	700	135	UKC 8/25/SA
		Adjustable big pneumatic	Mechanical spring	-	-	700	200	UKC 8/25/T
	5/2 monostable	Pneumatic	Mechanical spring	19	40	650	195	UKCA8
		Servo fed pneumatic	Mechanical spring	19	40	650	195	UKCA8/SA

* FOR THE PILOT ACTUATED VALVES OBTAINABLE WITH XVF4 SEE THE TABLE SOLENOID ACTUATED VALVES ON PAGE 2.64

** IF THE TYPE INCLUDES THE SUFFIX "/MR," THIS VALVE CAN BE USED TO SWITCH VACUUM

P.S.: ADD AT THE TYPE OF THE VALVES 3/2 THE LETTER "H" BETWEEN THE LETTERS "K" AND "A" (OR "C") TO ORDER 2/2 N.O. (OR 2/2 N.C.) VALVES.

E.G.: UKHA 8/12; UKHC 8/25

3 PORT SMALL PNEUMATIC

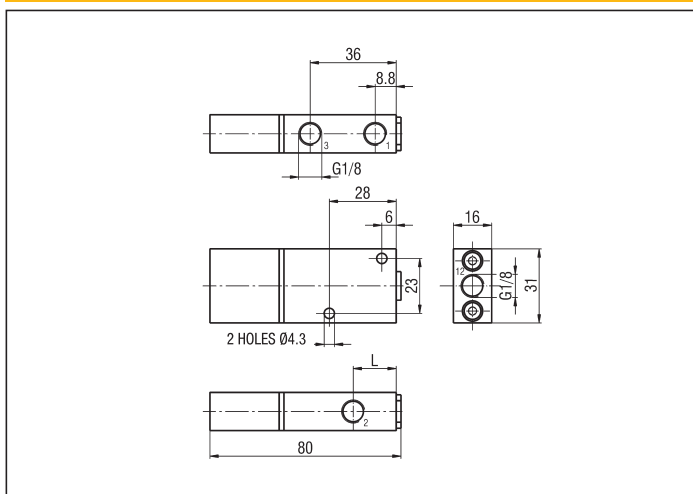

FUNCTION	L
3/2 N.O.	23
3/2 N.C.	18

3 PORT BIG PNEUMATIC

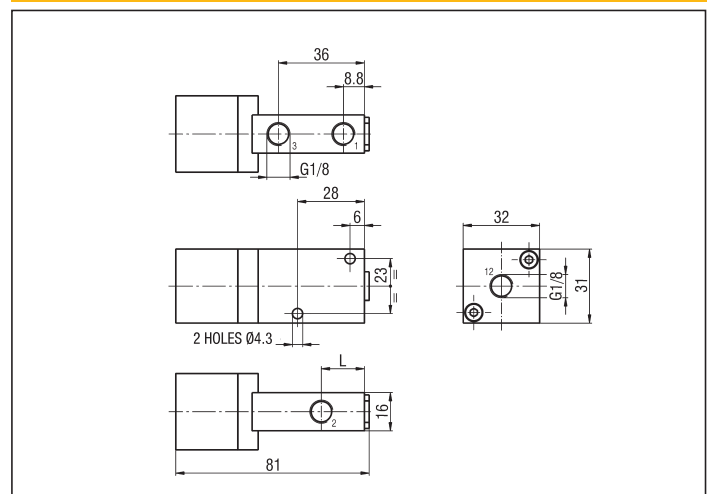

UKC 8/12/T

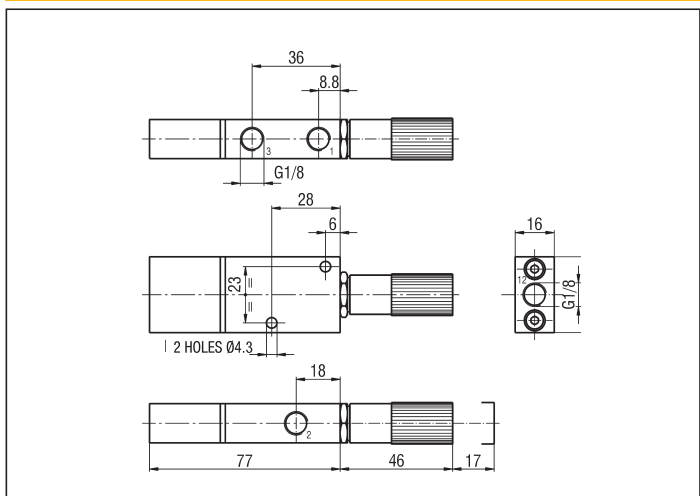

UKC 8/25/T

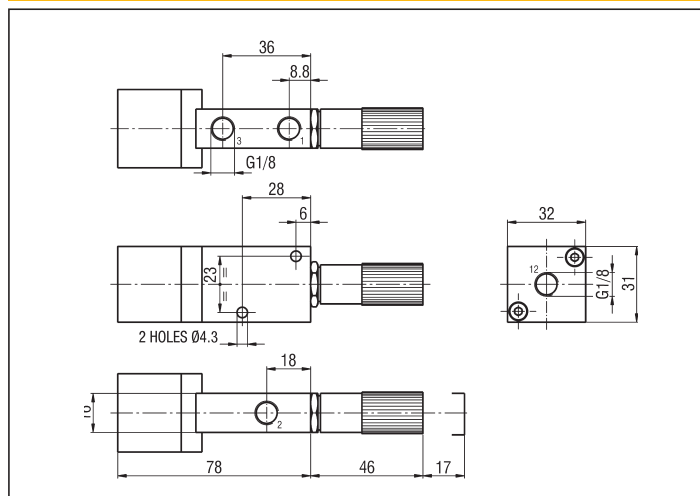

SPRING CALIBRATION UKC8/12/T

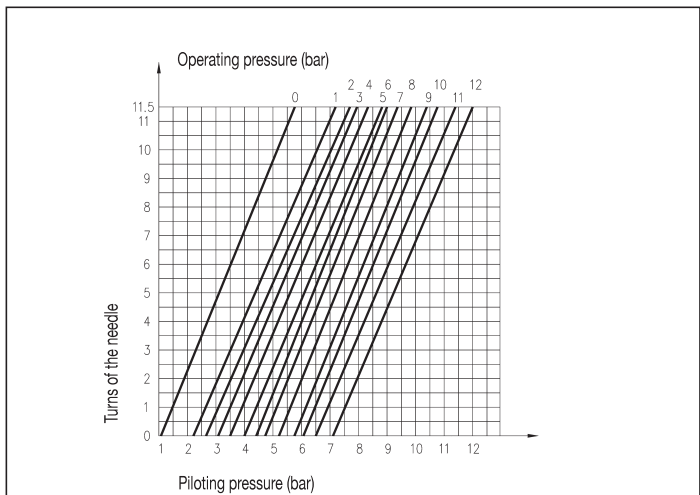

SPRING CALIBRATION UKC8/25/T

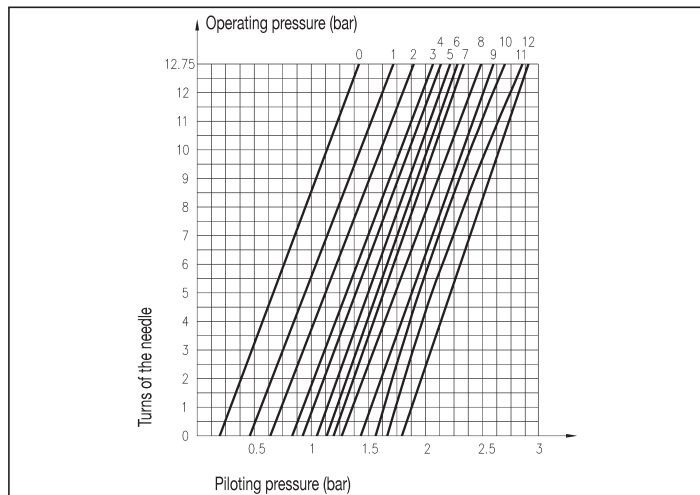

5 PORT

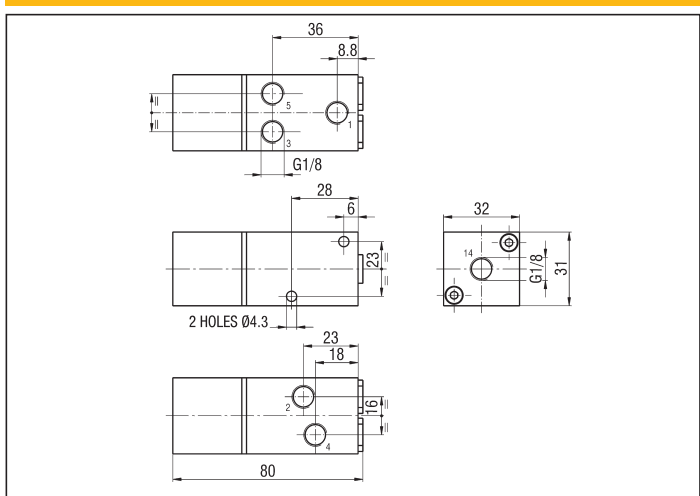

5 PORT WITH XVF4

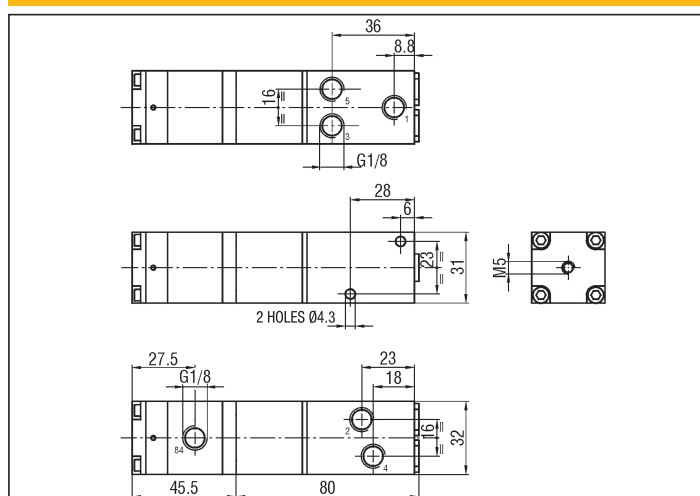

SOLENOID ACTUATED VALVES G 1/8 - 2, 3 and 5 PORT

Symbol	Function	Controls		Response time at 6 bar (ms)		Flow rate at 6 bar $\Delta P = 1$ bar (Nl/min)	Weight (g)	type
		Pilot	Return	Energized	De-energized			
	3/2 N.O. monostable	Small solenoid	Mechanical spring	10	28	700	108	UKA 8/12/U*
	3/2 N.C. monostable	Small solenoid	Mechanical spring	10	28	700	108	UKC 8/12/U*
	3/2 N.O. monostable	Big solenoid	Mechanical spring	18	38	700	135	UKA 8/25/U**
	3/2 N.C. monostable	Big solenoid	Mechanical spring	18	38	700	135	UKC 8/25/U**
	5/2 monostable	Solenoid	Mechanical spring	19	40	650	203	UKCA 8/U**

* TYPES OF THESE SOLENOID VALVES INCLUDE THE PILOTING SOLENOID VALVES "UMCSV" - SEE ON PAGE 2.3 (SPECIFY THE VOLTAGE IN THE ORDER)

** TYPES OF THESE SOLENOID VALVES DO NOT INCLUDE THE PILOTING SOLENOID VALVES (SEE ON PAGE 2.6 FOR "ULCSV/R" AND ON PAGE 2.13 FOR "C/USCSVG")

WHEREAS USING AS PILOT THE VALVE "XVF4" THE RESULT IS A LOW PRESSURE PILOT ACTUATED VALVE (FOR "XVF4" - SEE ON PAGE 3.37)

PS.: ADD AT THE TYPE OF THE VALVES 3/2 THE LETTER "H" BETWEEN THE LETTERS "K" AND "A" (OR "C") TO ORDER 2/2 N.O. (OR 2/2 N.C.) VALVES.

E.G.: UKHA 8/12/U; UKHC 8/25/U

3 PORT SMALL SOLENOID

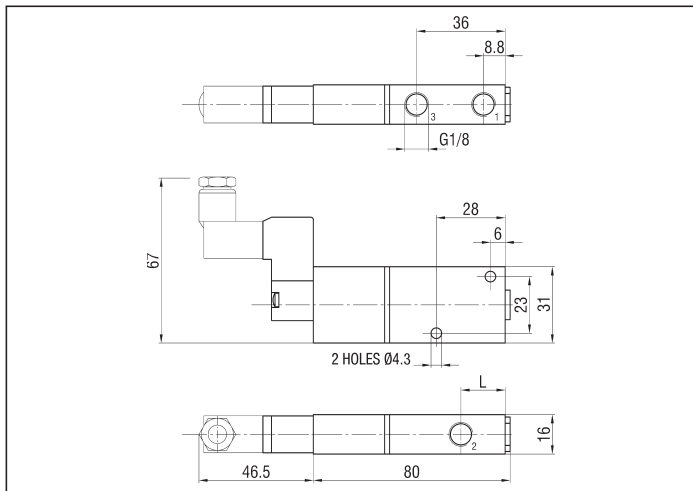

3 PORT BIG SOLENOID WITH ULCSV/R

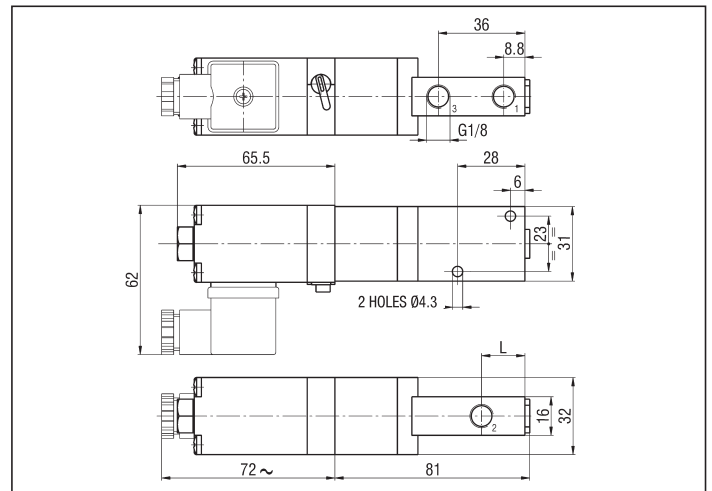

3 PORT BIG SOLENOID WITH C/USCSVG

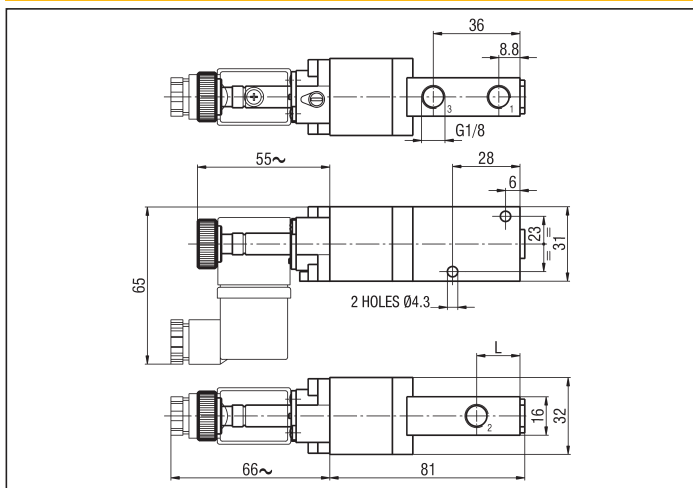

FUNCTION	L
3/2 N.O.	23
3/2 N.C.	18

5 PORT WITH ULCSV/R

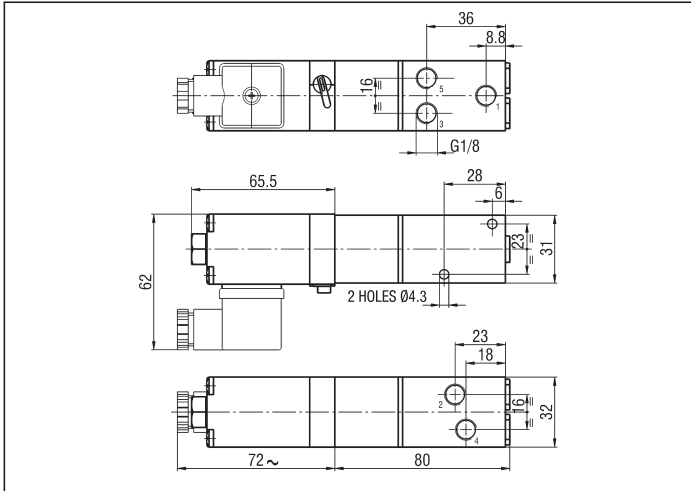

5 PORT WITH C/USCSVG

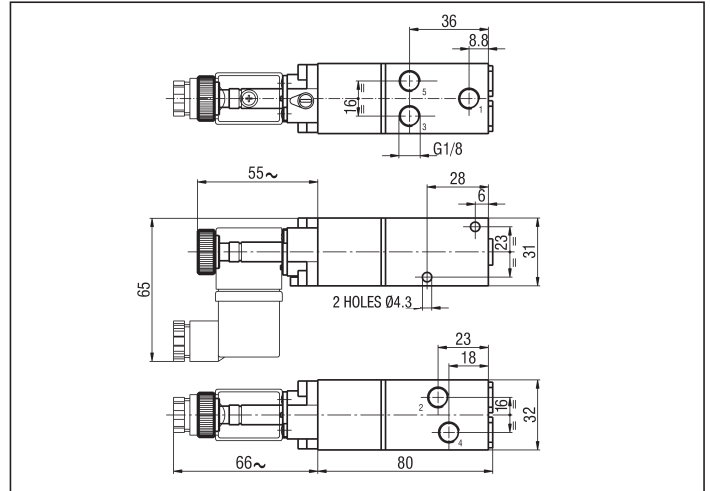

2

FIXED LENGTH BASE FOR MANIFOLD MOUNTING OF VALVES G 1/8 - CK8

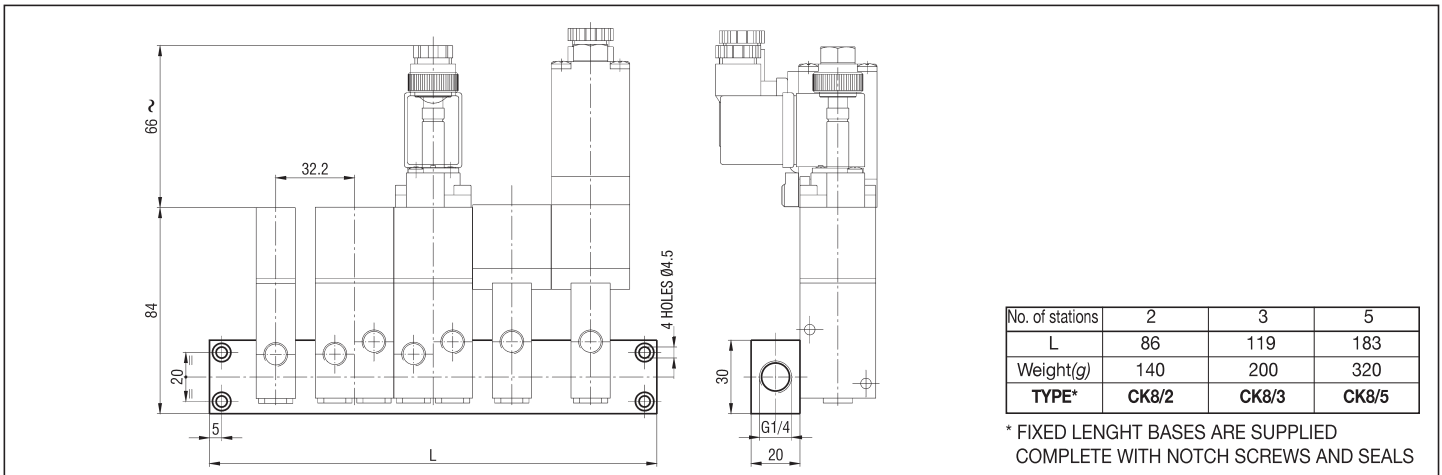

2

PILOT ACTUATED VALVES* G 1/4 - 2, 3 and 5 PORT

Symbol	Function	Controls		Response time at 6 bar (ms)		Flow rate at 6 bar $\Delta P = 1 \text{ bar (Nl/min)}$	Weight (g)	TYPE
		Pilot	Return	Energized	De-energized			
	3/2 N.O. monostable	Small pneumatic	Mechanical spring	20	30	950	225	UKA 4/16
	3/2 N.C. monostable	Small pneumatic	Mechanical spring	20	30	1100	225	UKC 4/16
		Servo fed small pneumatic	Mechanical spring	16	30	1100	225	UKC 4/16/SA
	3/2 N.O. monostable	Big pneumatic	Mechanical spring	20	30	950	280	UKA 4/32
	3/2 N.C. monostable	Big pneumatic	Mechanical spring	20	30	1100	280	UKC 4/32**
		Servo fed big pneumatic	Mechanical spring	20	28	1100	280	UKC 4/32/SA
	5/2 monostable	Pneumatic	Mechanical spring	24	45	1000	415	UKCA 4
		Servo fed pneumatic	Mechanical spring	24	45	1000	415	UKCA 4/SA

* FOR THE PILOT ACTUATED VALVES OBTAINABLE WITH "XVF4" SEE THE TABLE SOLENOID ACTUATED VALVES ON PAGE 2.67

** IF THE TYPE INCLUDES THE SUFFIX "/MR," THIS VALVE CAN BE USED TO SWITCH VACUUM

P.S.: ADD AT THE TYPE OF THE VALVES 3/2 THE LETTER "H" BETWEEN THE LETTERS "K" AND "A" (OR "C") TO ORDER 2/2 N.O. (OR 2/2 N.C.) VALVES.

E.G.: UKHA 4/16; UKHC 4/32

3 PORT SMALL PNEUMATIC

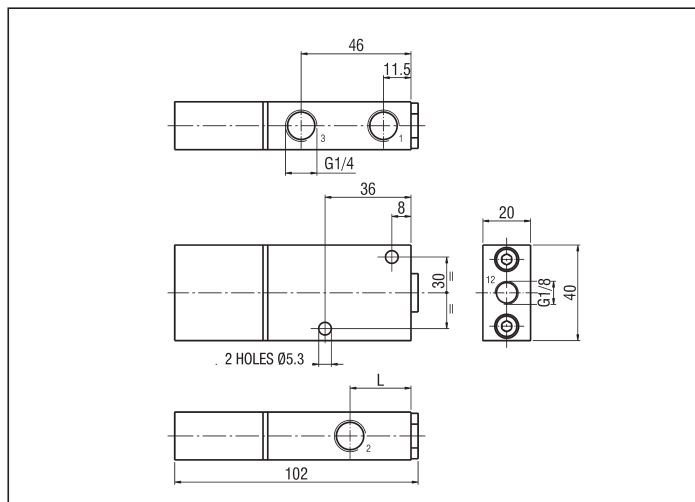

FUNCTION	L
3/2 N.O.	30
3/2 N.C.	25,5

3 PORT BIG PNEUMATIC

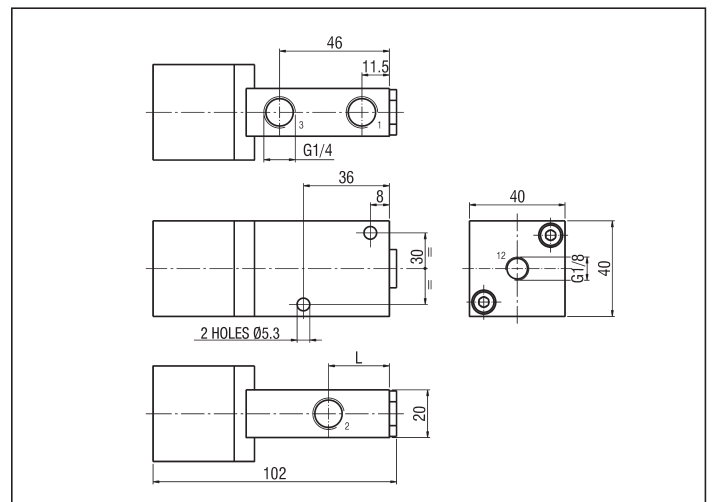

5 PORT

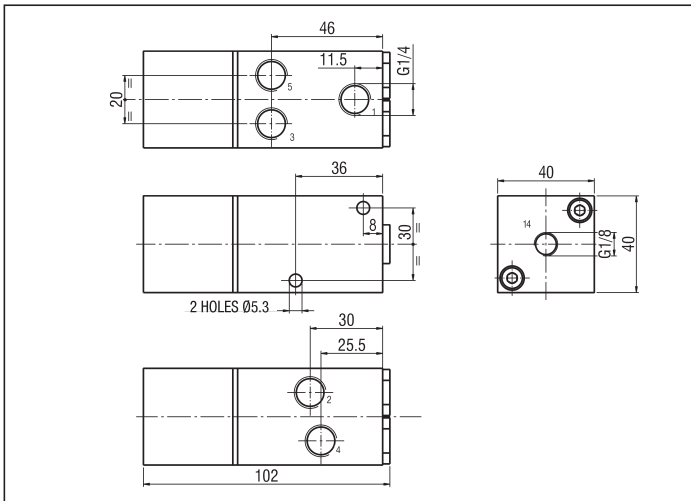

5 PORT WITH XVF4

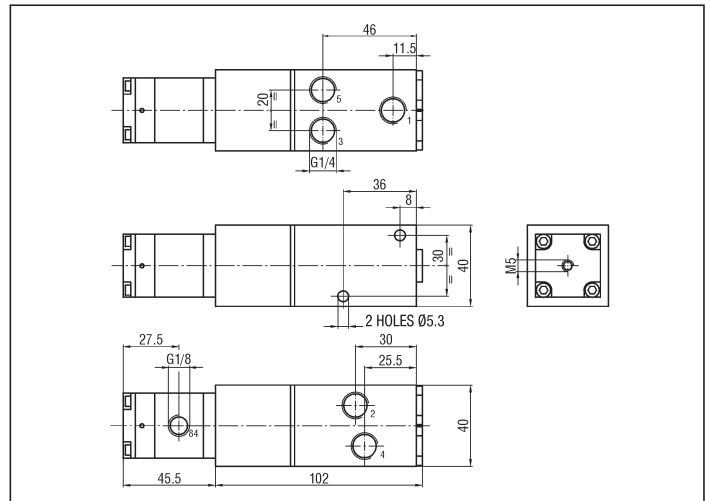

SOLENOID ACTUATED VALVES G 1/4 - 2, 3 and 5 PORT

Symbol	Function	Controls		Response time at 6 bar (ms)		Flow rate at 6 bar $\Delta P = 1 \text{ bar (Nl/min)}$	Weight (g)	TYPE
		Pilot	Return	Energized	De-energized			
	3/2 N.O. monostable	Small solenoid	Mechanical spring	10	28	950	225	UKA 4/16/U*
	3/2 N.C. monostable	Small solenoid	Mechanical spring	10	28	1100	230	UKC 4/16/U*
	3/2 N.O. monostable	Big solenoid	Mechanical spring	20	30	950	280	UKA 4/32/U**
	3/2 N.C. monostable	Big solenoid	Mechanical spring	20	30	1100	280	UKC 4/32/U**
	5/2 monostable	Solenoid	Mechanical spring	24	45	1000	415	UKCA 4/U**

* TYPES OF THESE SOLENOID VALVES INCLUDE THE PILOTING SOLENOID VALVES "UMCSV" - SEE ON PAGE 2.3 (SPECIFY THE VOLTAGE IN THE ORDER)

** TYPES OF THESE SOLENOID VALVES DO NOT INCLUDE THE PILOTING SOLENOID VALVES (SEE ON PAGE 2.6 FOR "ULCSV/R" AND ON PAGE 2.13 FOR "C/USCSVG")

WHEREAS USING AS PILOT THE VALVE "XVF4" THE RESULT IS A LOW PRESSURE PILOT ACTUATED VALVE (FOR "XVF4" - SEE ON PAGE 3.37)

PS.: ADD AT THE TYPE OF THE VALVES 3/2 THE LETTER "H" BETWEEN THE LETTERS "K" AND "A" (OR "C") TO ORDER 2/2 N.O. (OR 2/2 N.C.) VALVES.

E.G.: UKHA 4/16/U; UKHC 4/32/U

3 PORT SMALL SOLENOID

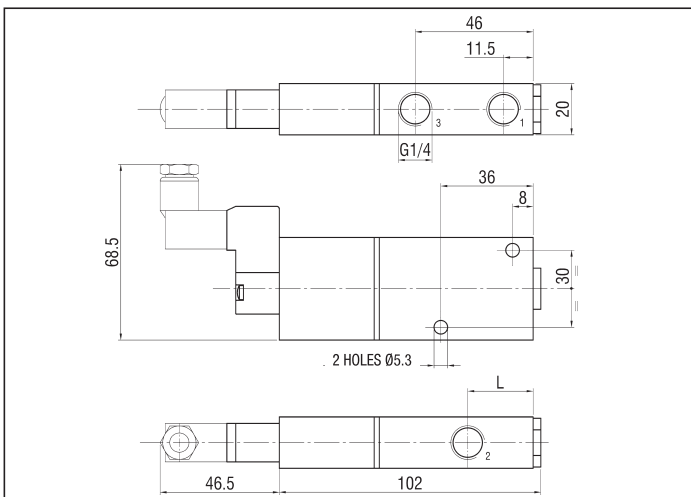

3 PORT BIG SOLENOID WITH ULCSV/R

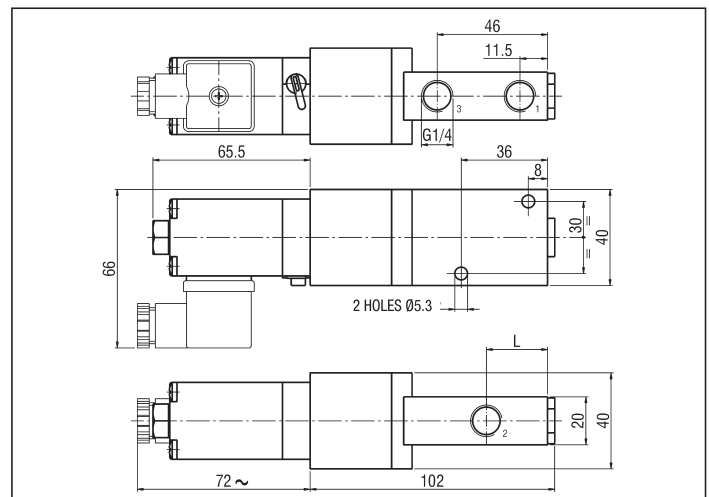

2

3 PORT BIG SOLENOID WITH C/USCSVG

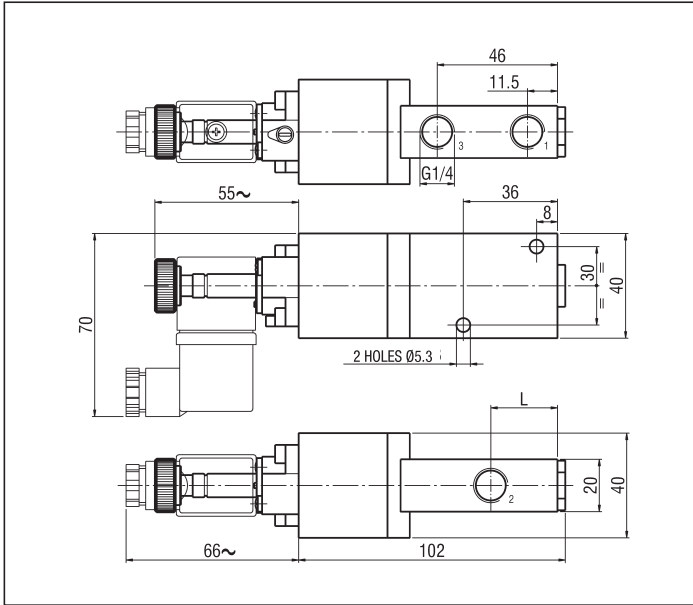

5 PORT WITH ULCSV/R

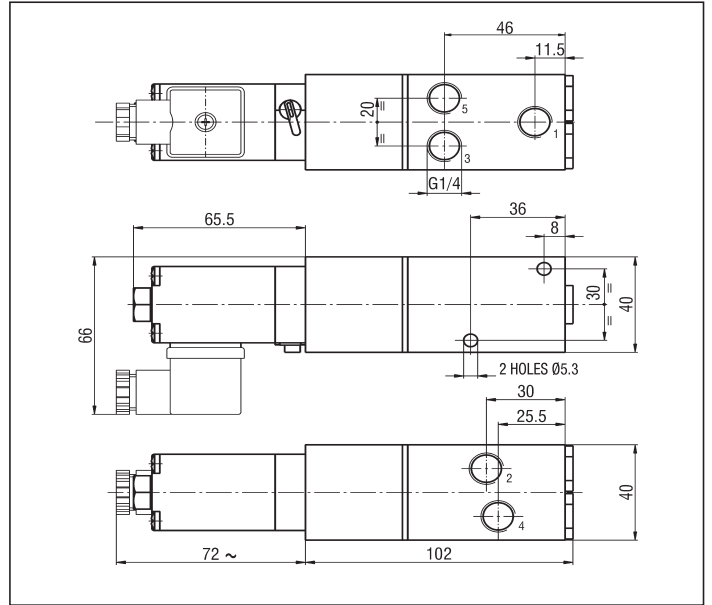

5 PORT WITH C/USCSVG

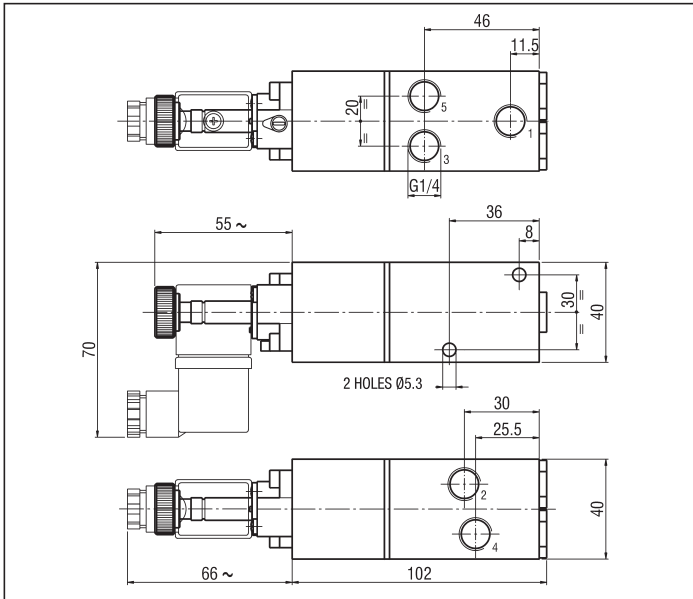

FUNCTION	L
3/2 N.O.	30
3/2 N.C.	25,5

FIXED LENGTH BASE FOR MANIFOLD MOUNTING OF VALVES G 1/4 - CK4

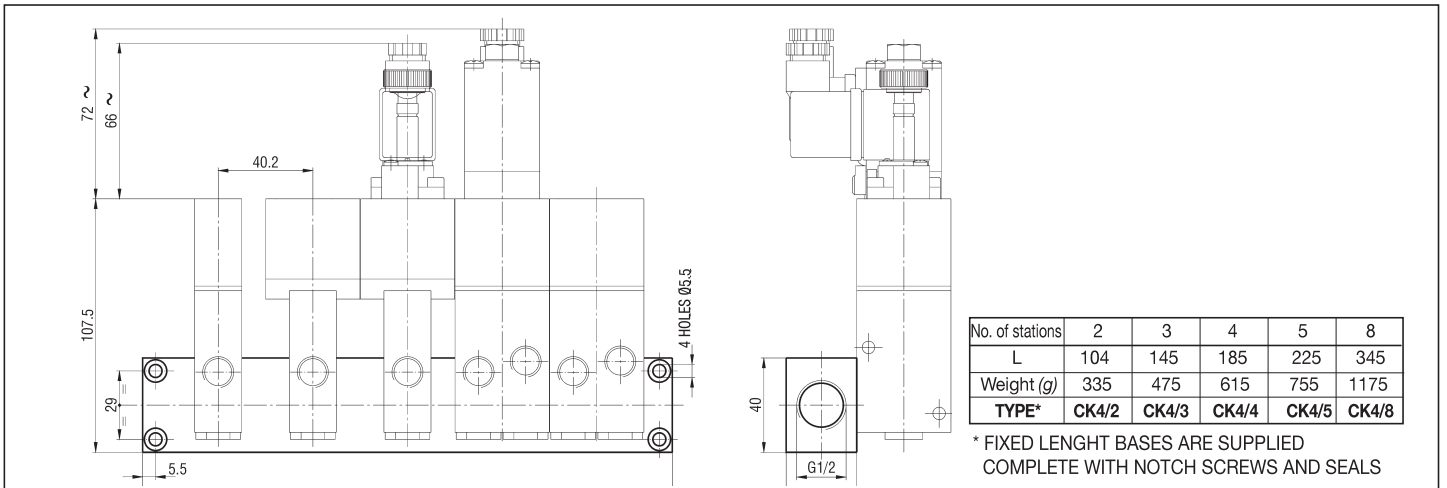

No. of stations	2	3	4	5	8
L	104	145	185	225	345
Weight (g)	335	475	615	755	1175
TYPE*	CK4/2	CK4/3	CK4/4	CK4/5	CK4/8

* FIXED LENGTH BASES ARE SUPPLIED COMPLETE WITH NOTCH SCREWS AND SEALS

PILOT ACTUATED VALVES* G 1/2 - 2, 3 and 5 PORT

Symbol	Function	Controls		Response time at 6 bar (ms)		Flow rate at 6 bar $\Delta P = 1 \text{ bar (Nl/min)}$	Weight (g)	TYPE
		Pilot	Return	Energized	De-energized			
	3/2 N.O. monostable	Small pneumatic	Mechanical spring	24	32	1900	420	UKA 2/20
	3/2 N.C. monostable	Small pneumatic	Mechanical spring	24	32	2100	420	UKC 2/20
		Servo fed small pneumatic	Mechanical spring	25	32	2100	520	UKC 2/20/SA
	3/2 N.O. monostable	Big pneumatic	Mechanical spring	24	32	1900	520	UKA 2/40
	3/2 N.C. monostable	Big pneumatic	Mechanical spring	24	32	2100	520	UKC 2/40**
		Servo fed big pneumatic	Mechanical spring	20	30	2100	520	UKC 2/40/SA
	5/2 monostable	Pneumatic	Mechanical spring	24	40	2000	800	UKCA 2
		Servo fed pneumatic	Mechanical spring	24	40	2000	800	UKCA 2/SA

* FOR THE PILOT ACTUATED VALVES OBTAINABLE WITH "XVF4" SEE THE TABLE SOLENOID ACTUATED VALVES ON PAGE 2.70

** IF THE TYPE INCLUDES THE SUFFIX "/MR," THIS VALVE CAN BE USED TO SWITCH VACUUM

P.S.: ADD AT THE TYPE OF THE VALVES 3/2 THE LETTER "H" BETWEEN THE LETTERS "K" AND "A" (OR "C") TO ORDER 2/2 N.O. (OR 2/2 N.C.) VALVES.

E.G.: UKHA 2/20; UKHC 2/20

3 PORT SMALL PNEUMATIC

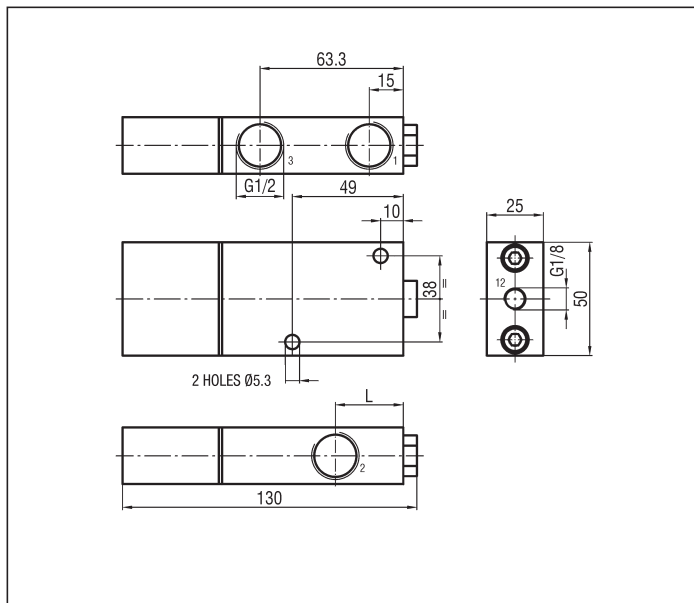

3 PORT BIG PNEUMATIC

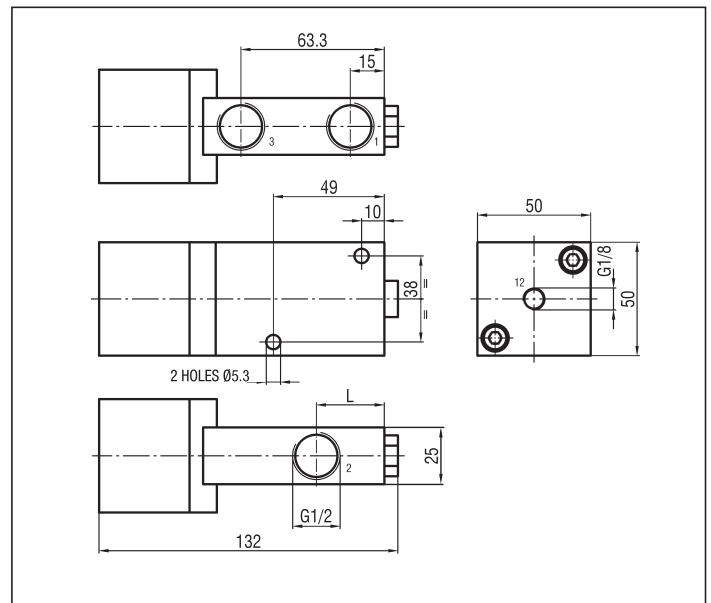

FUNCTION	L
3/2 N.O.	40
3/2 N.C.	30

5 PORT

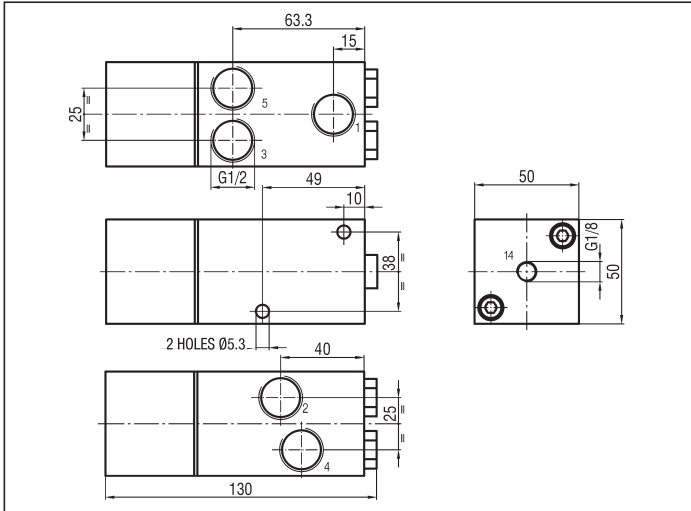

5 PORT WITH XVF4

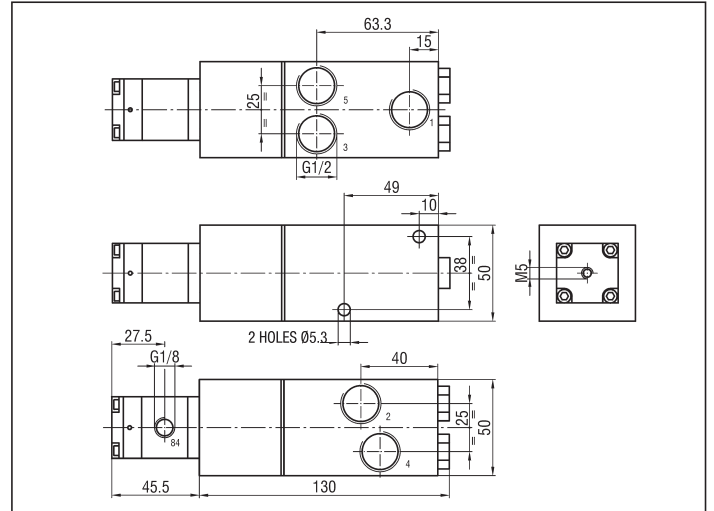

SOLENOID ACTUATED VALVES G 1/2 - 2, 3 and 5 PORT

Symbol	Function	Controls		Response time at 6 bar (ms)		Flow rate at 6 bar ΔP = 1 bar (Nl/min)	Weight (g)	TYPE
		Pilot	Return	Energized	De-energized			
	3/2 N.O. monostable	Small solenoid	Mechanical spring	24	32	1900	430	UKA 2/20/U*
	3/2 N.C. monostable	Small solenoid	Mechanical spring	24	32	2100	440	UKC 2/20/U*
	3/2 N.O. monostable	Big solenoid	Mechanical spring	24	32	1900	530	UKA 2/40/U**
	3/2 N.C. monostable	Big solenoid	Mechanical spring	24	32	2100	540	UKC 2/40/U**
	5/2 monostable	Solenoid	Mechanical spring	24	32	2000	810	UKCA 2/U**

* TYPES OF THESE SOLENOID VALVES INCLUDE THE PILOTING SOLENOID VALVES "UMCSV" - SEE ON PAGE 2.3 (SPECIFY THE VOLTAGE IN THE ORDER)

** TYPES OF THESE SOLENOID VALVES DO NOT INCLUDE THE PILOTING SOLENOID VALVES (SEE ON PAGE 2.6 FOR "ULCSV/R" AND ON PAGE 2.13 FOR "C/USCSVG") WHEREAS USING AS PILOT THE VALVE "XVF4" THE RESULT IS A LOW PRESSURE PILOT ACTUATED VALVE (FOR "XVF4" - SEE ON PAGE 3.37)

PS.: ADD AT THE TYPE OF THE VALVES 3/2 THE LETTER "H" BETWEEN THE LETTERS "K" AND "A" (OR "C") TO ORDER 2/2 N.O. (OR 2/2 N.C.) VALVES.

3 PORT SMALL SOLENOID

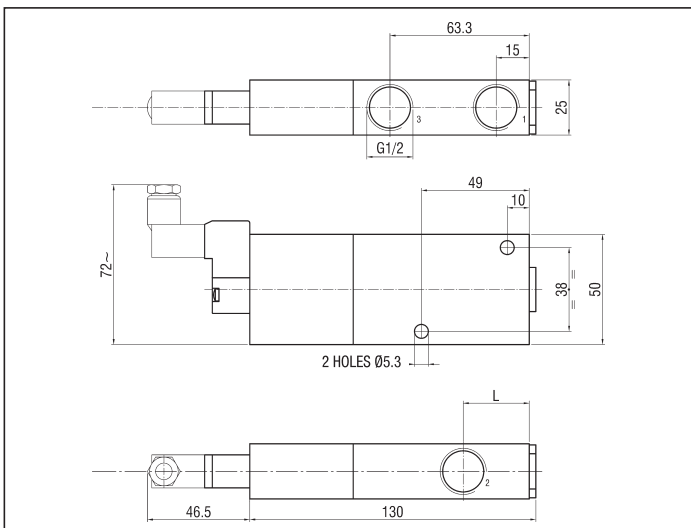

3 PORT BIG SOLENOID WITH ULCSV/R

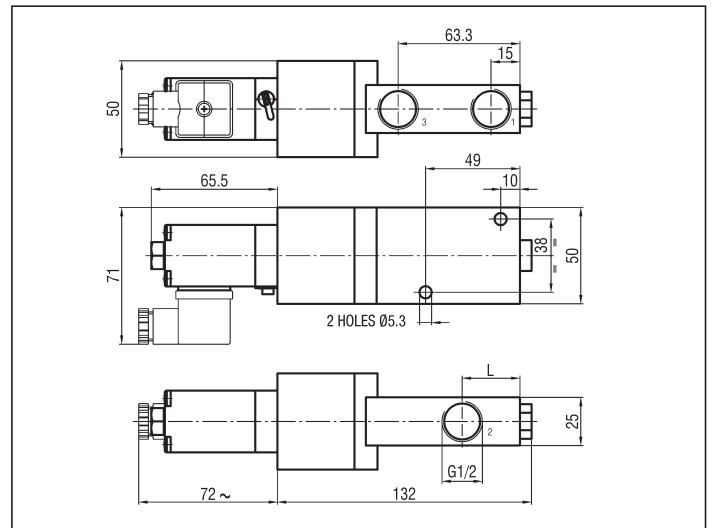

3 PORT BIG SOLENOID WITH C/USCSVG

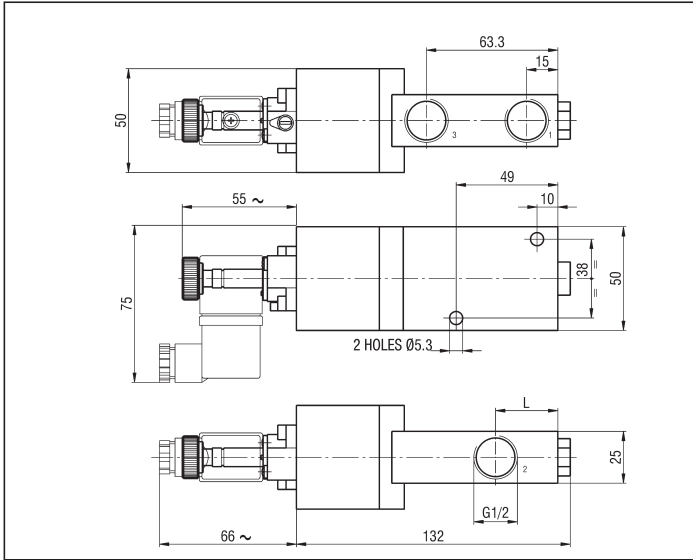

5 PORT WITH ULCSV/R

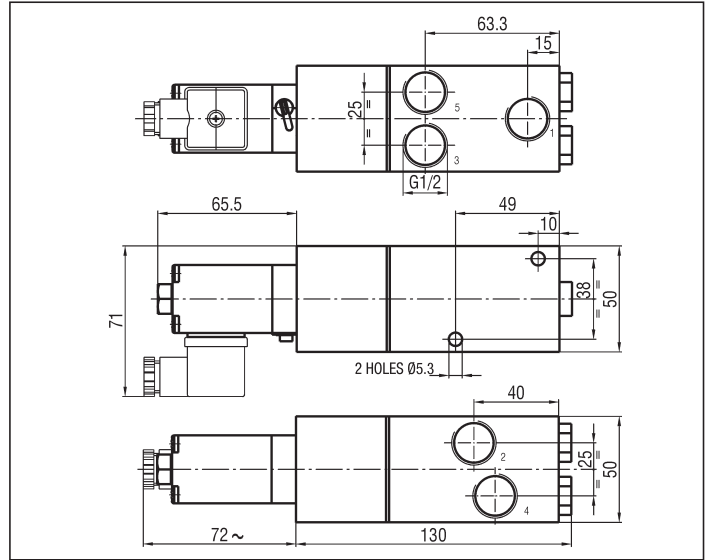

5 PORT WITH C/USCSVG

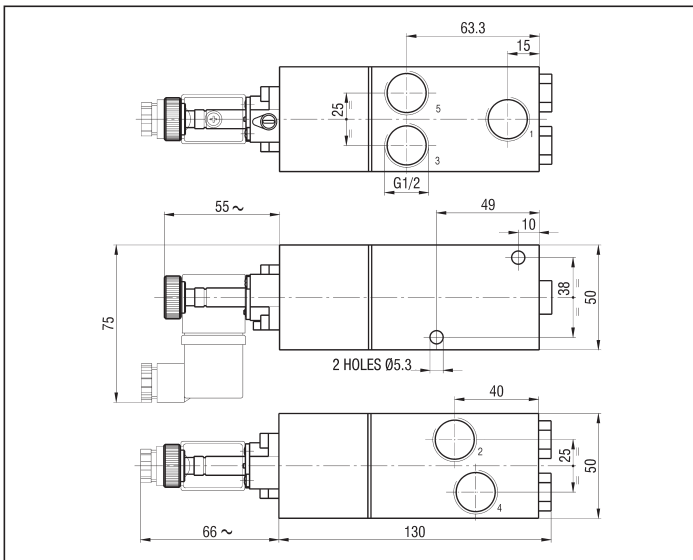

FUNCTION	L
3/2 N.O.	40
3/2 N.C.	30

FIXED LENGTH BASE FOR MANIFOLD MOUNTING OF VALVES G 1/2 - CK2

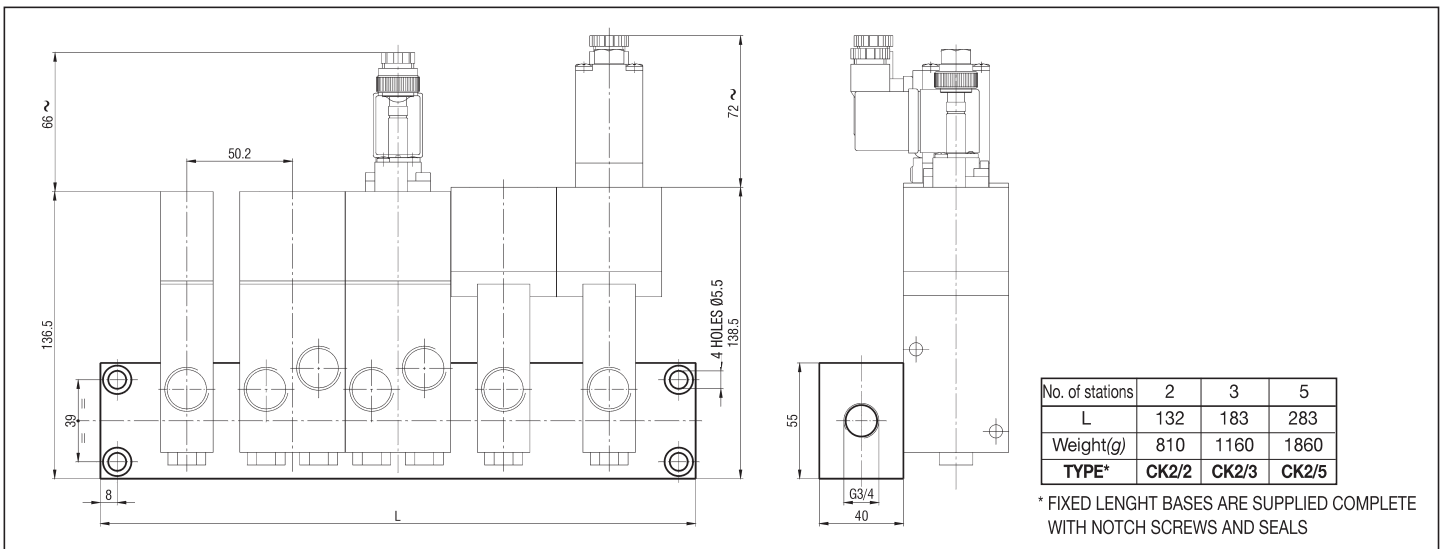

No. of stations	2	3	5
L	132	183	283
Weight(g)	810	1160	1860
TYPE*	CK2/2	CK2/3	CK2/5

* FIXED LENGTH BASES ARE SUPPLIED COMPLETE WITH NOTCH SCREWS AND SEALS

PILOT ACTUATED VALVES* G 1 - 2, 3 AND 5 PORT

Symbol	Function	Controls		Response time at 6 bar (ms)		Flow rate at 6 bar $\Delta P = 1$ bar (NI/min)	Weight (g)	TYPE
		Pilot	Return	Energized	De-energized			
	3/2 N.O. monostable	Small pneumatic	Mechanical spring	40	65	11300	2550	UKA 1
	3/2 N.C. monostable	Small pneumatic	Mechanical spring	40	65	7800	2550	UKC 1**
	5/2 monostable	Pneumatic	Mechanical spring	40	70	8050	5160	UKCA 1

* FOR THE PILOT ACTUATED VALVES OBTAINABLE WITH "XVF4" SEE THE TABLE SOLENOID ACTUATED VALVES ON PAGE 2.73

** IF THE TYPE INCLUDES THE SUFFIX "/MR," THIS VALVE CAN BE USED TO SWITCH VACUUM

P.S.: ADD AT THE TYPE OF THE VALVES 3/2 THE LETTER "H" BETWEEN THE LETTERS "K" AND "A" (OR "C") TO ORDER 2/2 N.O. (OR 2/2 N.C.) VALVES. E.G.: UKHA 1; UKHC 1

UKA 1 - UKC 1

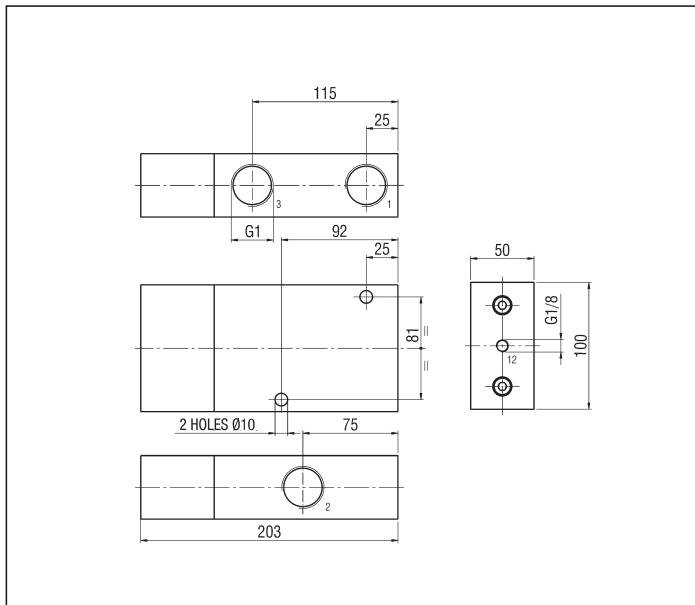

UKCA 1

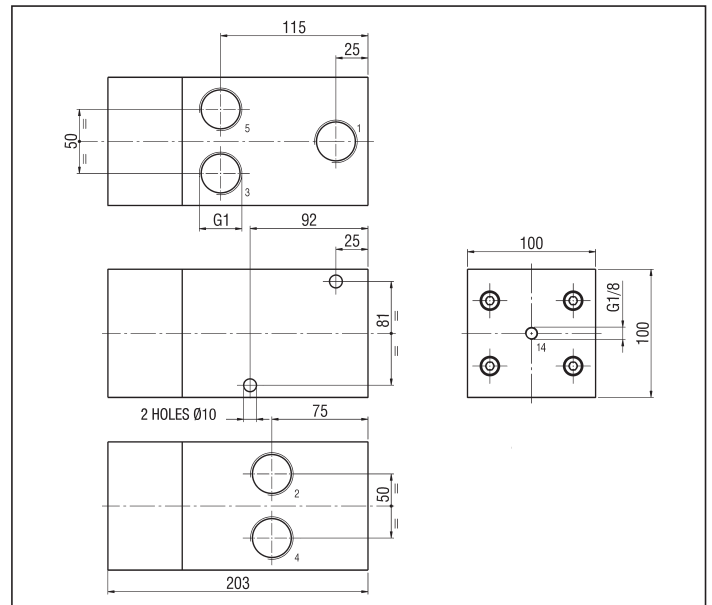

3 PORT WITH XVF4

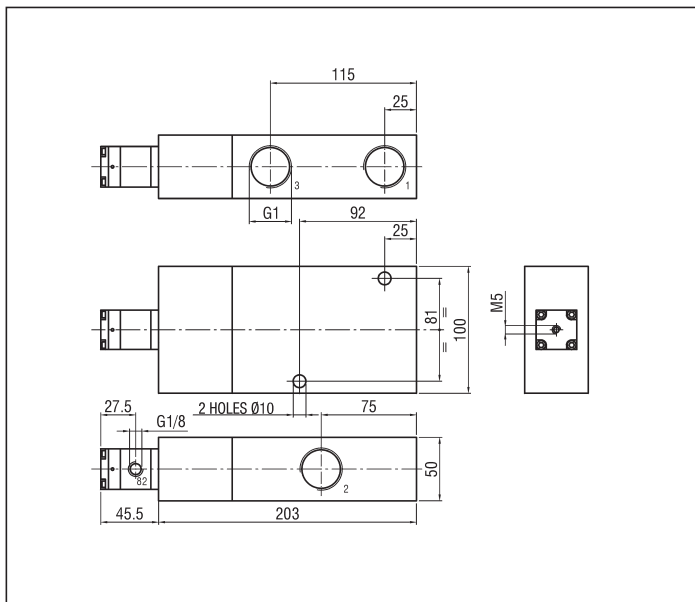

5 PORT WITH XVF4

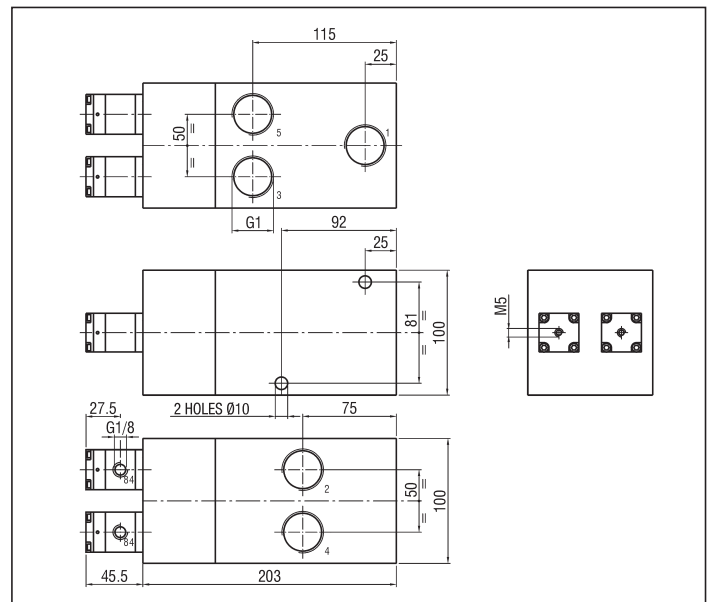

SOLENOID ACTUATED VALVES G 1 - 2, 3 AND 5 PORT

Symbol	Function	Controls		Response time at 6 bar (ms)		Flow rate at 6 bar $\Delta P = 1$ bar (Nl/min)	Weight (g)	TYPE*
		Pilot	Return	Energized	De-energized			
	3/2 N.O. monostable	Small solenoid	Mechanical spring	40	65	11300	2600	UKA 1/U
	3/2 N.C. monostable	Small solenoid	Mechanical spring	40	65	7800	2550	UKC 1/U
	5/2 monostable	Solenoid	Mechanical spring	40	70	8050	5100	UKCA 1/U

* THE TYPES OF THE SOLENOID VALVES DO NOT INCLUDE THE PILOTING SOLENOID VALVES (SEE ON PAGE 2.6 FOR "ULCSV/R" AND ON PAGE 2.13 FOR "C/USCSVG") WHEREAS USING AS PILOT THE VALVE "XVF4" THE RESULT IS A LOW PRESSURE PILOT ACTUATED VALVE (FOR "XVF4" - SEE ON PAGE 3.37)
 P.S.: ADD AT THE TYPE OF THE VALVES 3/2 THE LETTER "H" BETWEEN THE LETTERS "K" AND "A" (OR "C") TO ORDER 2/2 N.O. (OR 2/2 N.C.) VALVES.
 E.G.: UKHA 1/U; UKHC 1/U

3 PORT WITH ULCSV/R

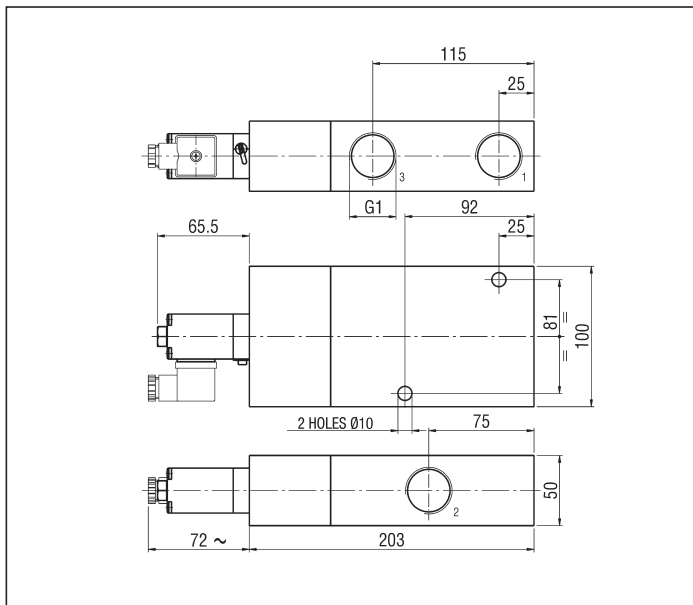

3 PORT WITH C/USCSVG

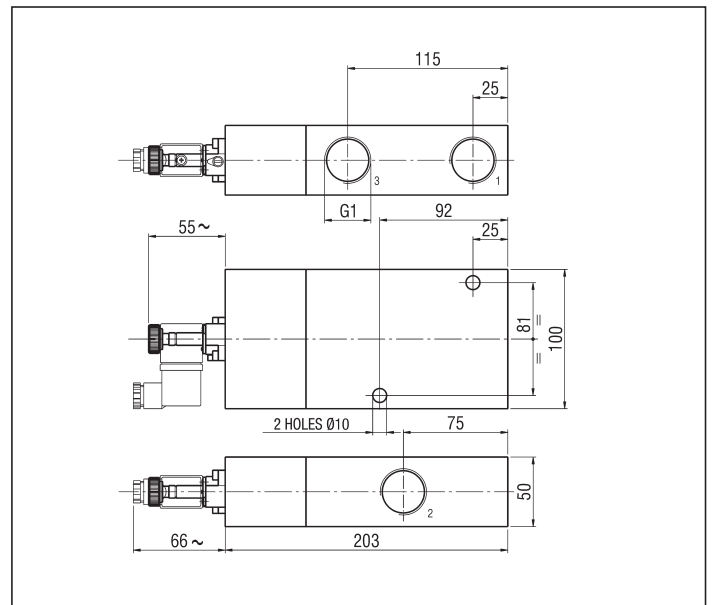

5 PORT WITH ULCSV/R

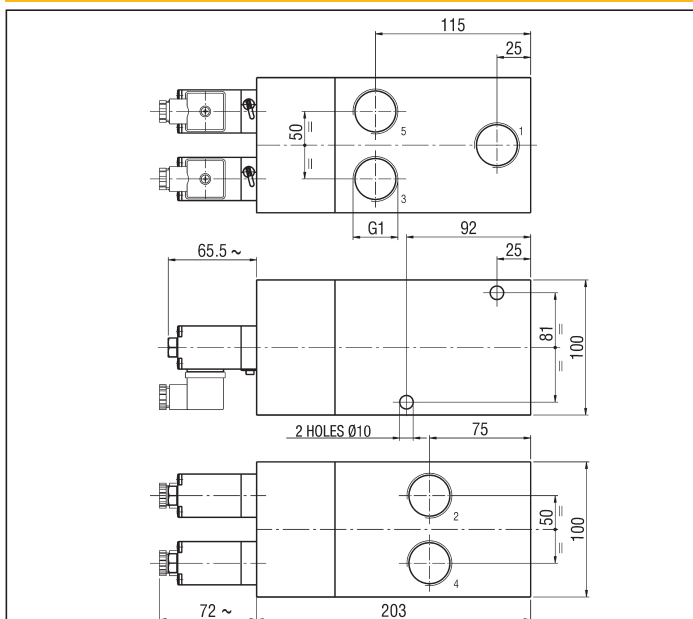

5 PORT WITH C/USCSVG

